

**ICA-SJTU**

# **User Guide**

**Heat Exchanger Simulation for  
Refrigeration**

## **User Guide for Heat Exchanger Simulation for Refrigeration**

**Submitted by:**

**Prof. Guoliang Ding**

**Institute of Refrigeration & Cryogenics**

**Dept. of Power & Energy Engineering**

**Shanghai Jiao Tong University**

**Date: 2018-06-30**

# Content

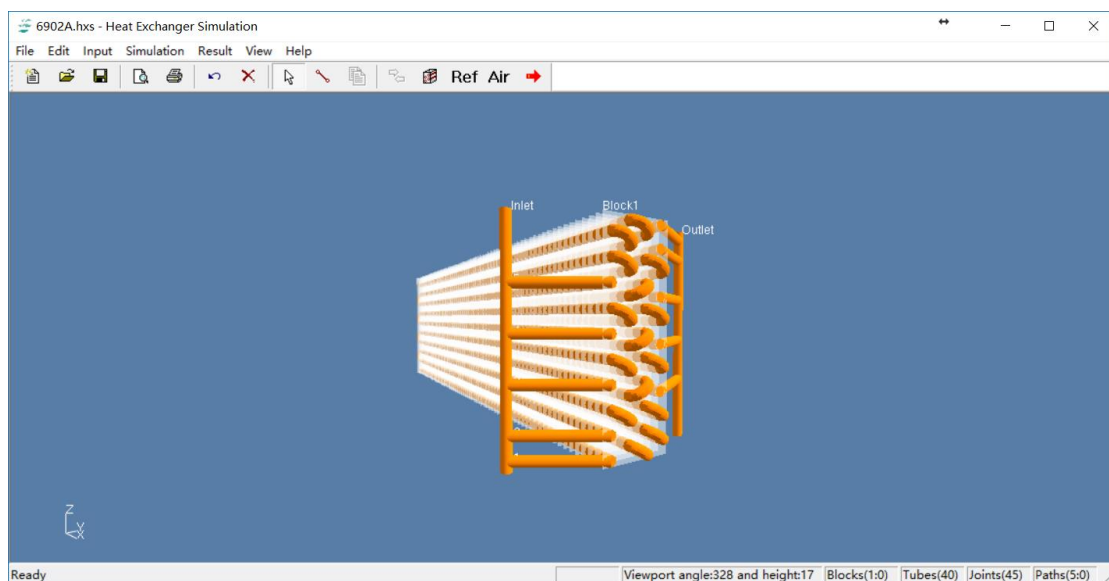
<b>1 Overview .....</b>	<b>1</b>
<b>2 Installation .....</b>	<b>3</b>
2.1 System & hardware requirement.....	3
2.2 How to install the program.....	3
<b>3 Main menu .....</b>	<b>5</b>
3.1 Submenu of File .....	6
3.2 Submenu of Edit.....	7
3.3 Submenu of Input.....	8
3.4 Submenu of Simulate .....	9
3.5 Submenu of Result .....	9
3.6 Submenu of View.....	10
<b>4 Menu in result window .....</b>	<b>11</b>
4.1 Submenu of File .....	11
4.2 Submenu of View.....	11
<b>5 Toolbar .....</b>	<b>12</b>
<b>6 Data input windows .....</b>	<b>12</b>
6.1 General data input window .....	12
6.2 Refrigerant status input window .....	12
6.3 Inlet airflow input window.....	13
6.4 Heat exchanger dimension input window .....	16
6.5 Tube structure input window .....	18
6.6 Fin type input window .....	21
6.7 Joint input window.....	22
<b>7 Connect Tubes .....</b>	<b>23</b>
7.1 How to connect tubes.....	23
7.2 Copy selected paths.....	30
7.3 Status bar.....	31
<b>8 Run a simulation .....</b>	<b>31</b>
8.1 Run a simulation .....	31
8.2 Exception handling .....	32
<b>9 Simulation results output windows .....</b>	<b>32</b>
9.1 (New) General results .....	33
9.2 General results window.....	33

9.3 Simulation results of joints.....	34
9.4 Simulation results of path.....	34
9.5 Show results as colored Graph.....	35
9.5 Export Report Form .....	37
<b>10 Operation steps and examples .....</b>	<b>38</b>
10.1 Operation steps.....	38
10.2 Example of operation steps for I typed heat exchanger .....	39
10.3 Example of operation steps for L typed heat exchanger .....	48
10.4 Example of operation steps for C typed heat exchanger .....	54

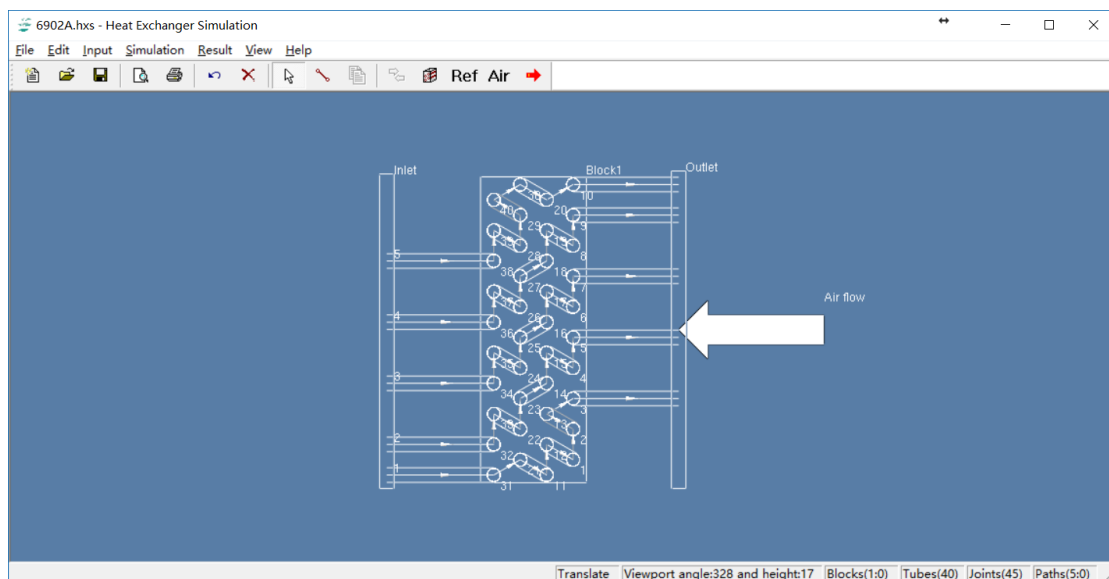
# 1 Overview

The basic and main function of Fin-and-Tube Heat Exchanger Simulation Software is to give accurate calculation results for predicting the capability of fin-and-tube heat exchangers in steady state condition, such as heat exchange capacity, pressure drop of refrigerant side or air side and etc. once the input parameters are given. The Fin-and-Tube Heat Exchanger Simulation Software can provide a graphical user interface to help users to enter data and observe simulation results, and both 3D and 2D graphic user interfaces are available.

The Fin-and-Tube Heat Exchanger Simulation Software can simulate fin-and-tube heat exchangers, and the interface of which are shown in Fig.1-1. The detailed architecture and functionality of HXSim will be introduced hereinafter.



(a) 3D View



(b) 2D View

**Fig. 1-1 Graphic user interface of HXSim**

### (1) Architecture of HXSim

The architecture of HXSim is shown in Fig. 1-2. Users can input parameters such as dimensions of heat exchanger, tube and fin geometry, refrigerant circuitry and operating conditions through the interactive GUI. The simulation package will output parameters such as heat exchange, outlet conditions of both refrigerant and air. All of the calculated results will be shown in tables and charts as well as 3D colored graph.

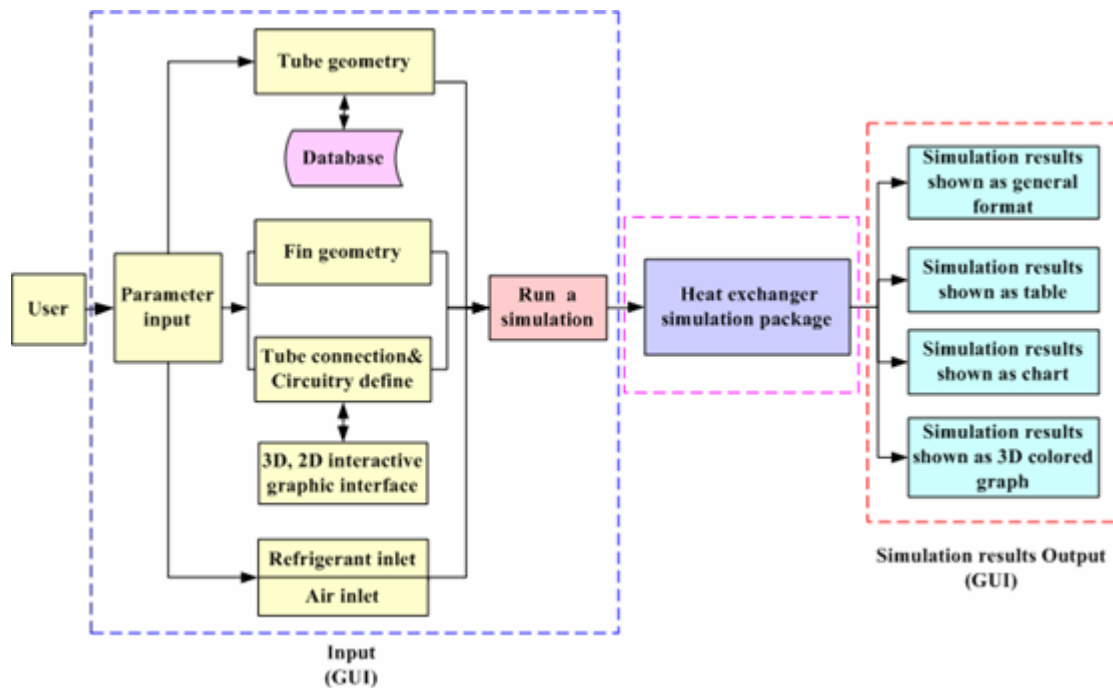


Fig. 1-2 Architecture of HXSim

### (2) Functionality of HXSim

The main functions of HXSim are listed as follows:

- a. Simulate heat exchanger in steady state condition
- b. 3D graphic user interface to help user to enter data and view simulation results
- c. 2D & 3D interactive graphic interface which allow user to define complex tube circuitry
- d. Database is introduced, which help user to manage fins, wires and tubes parameter
- e. Define fin pitch
- f. Show results as 3D colored graph
- g. Export report forms of simulation results
- h Show simulation results as table
- i. Saving and loading file serialized

## 2 Installation

### 2.1 System & hardware requirement

**Operation system:** Windows 10/ Windows 7/ Window 8

**Preinstalled:** AccessDatabaseEngine 2007

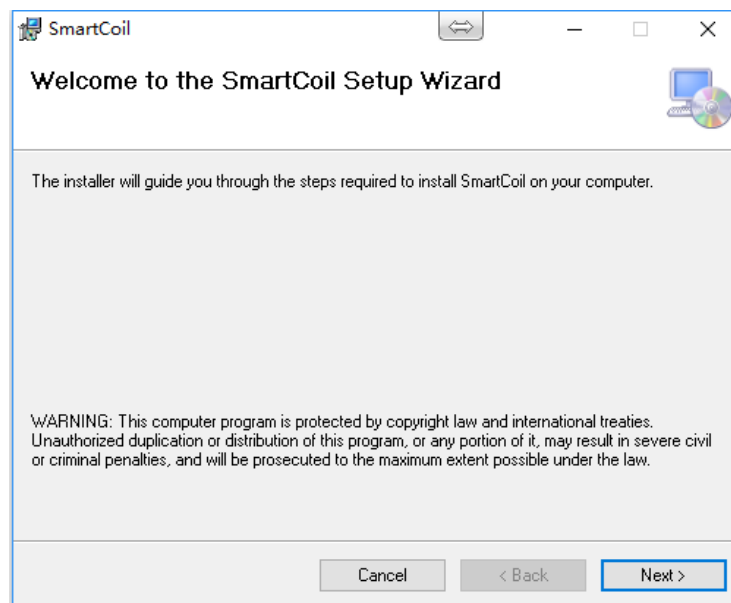
**Hardware configuration:**

Minimum: RAM: 128 MB, Hard Disk: 20G, CPU: P3 650 MHZ

Recommended: RAM: 512/1024 MB, Hard Disk: 40G, CPU: P4 2.4 G, GPU: NVIDIA  
Geforce 5200/ ATI Radeon 9550

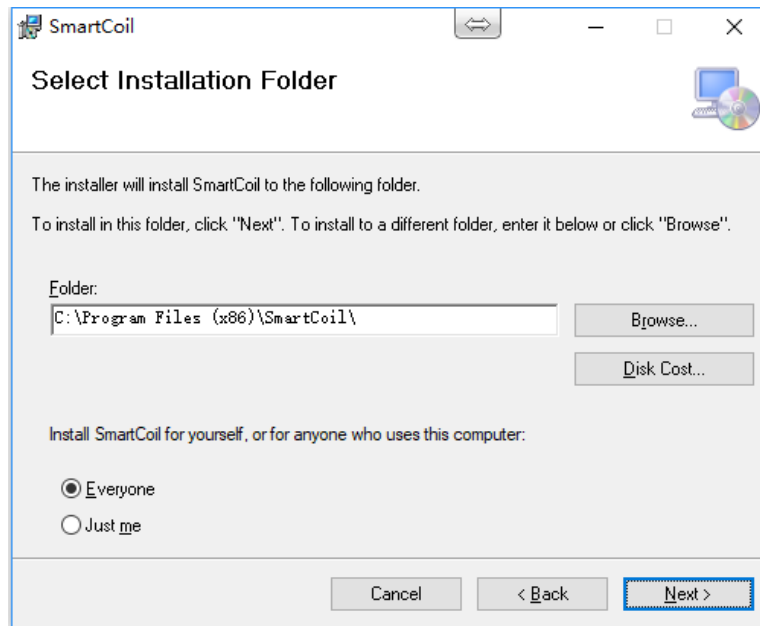
### 2.2 How to install the program

The installation process of HXSim seems as most of software used in Windows Operation System such as Office. Double click the installation package “HXSim v2.01 Setup.msi”, and the following dialog will be popped out. Click button “Next” to continue installation, and click “Cancel” to exist the installation.



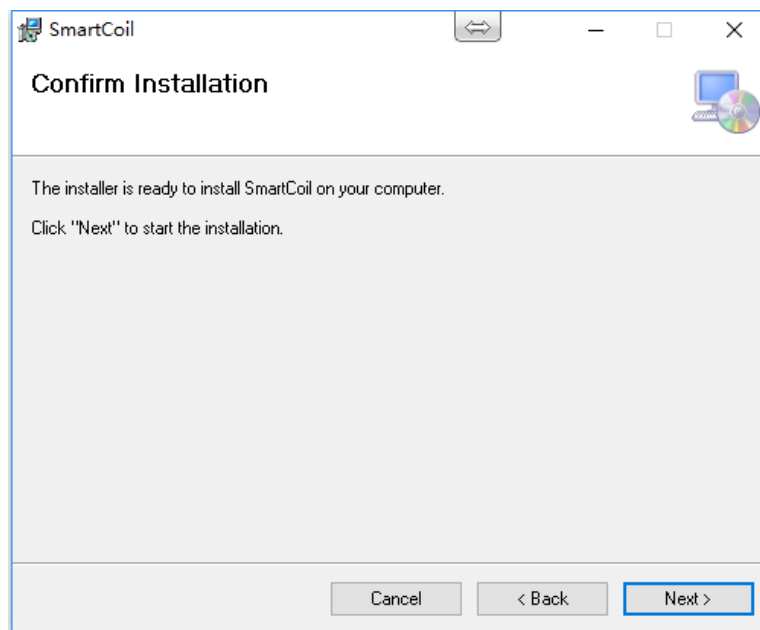
**Fig. 2-1 Start software installation**

User can change the destination folder to install this software as shown in Fig.2-3.

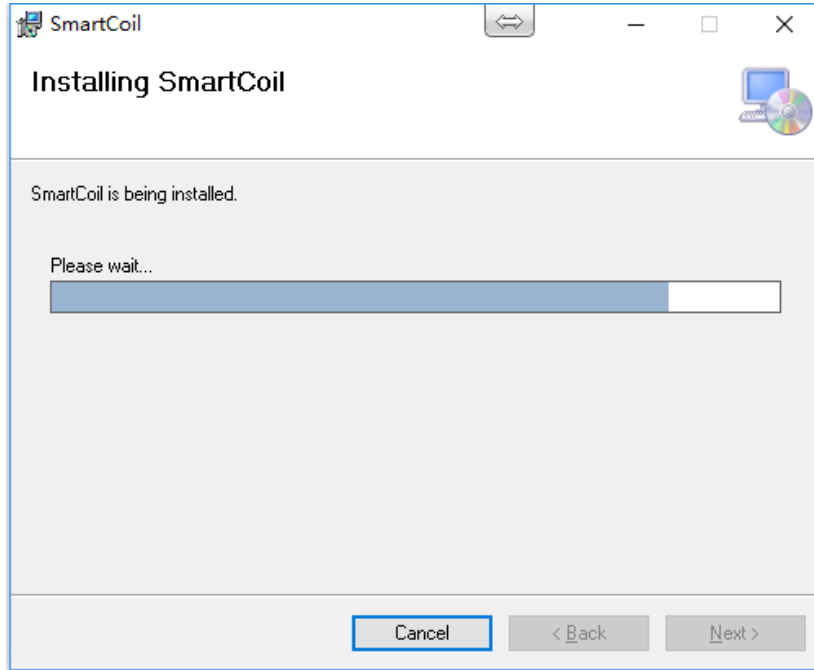


**Fig. 2-2 Destination Folder**

After finished all installation settings, user can click button “Next” to begin the installation.

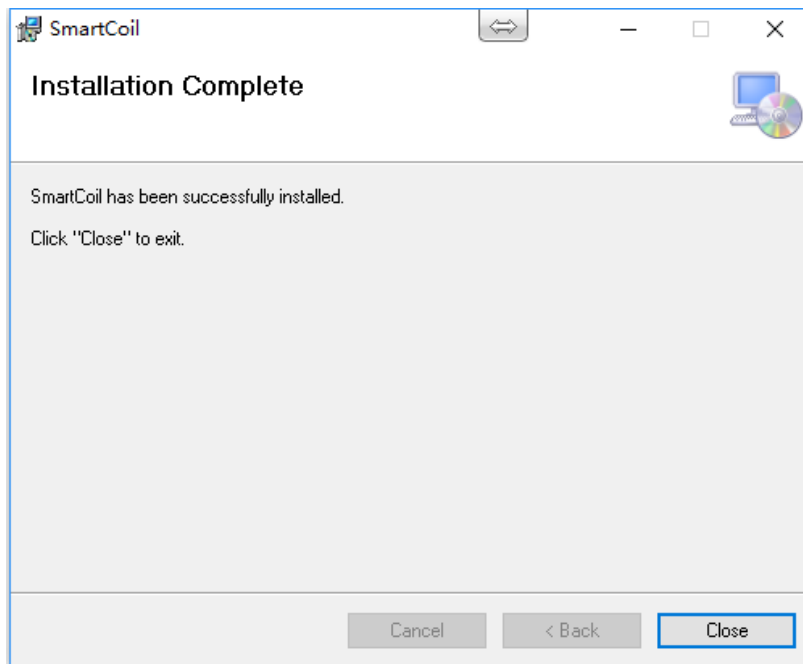


**Fig. 2-3 ready to install the software**



**Fig. 2-4 Installation process**

After all components of software have been installed successfully, the following dialog will be popped out. Click button “Finish” to complete the installation.



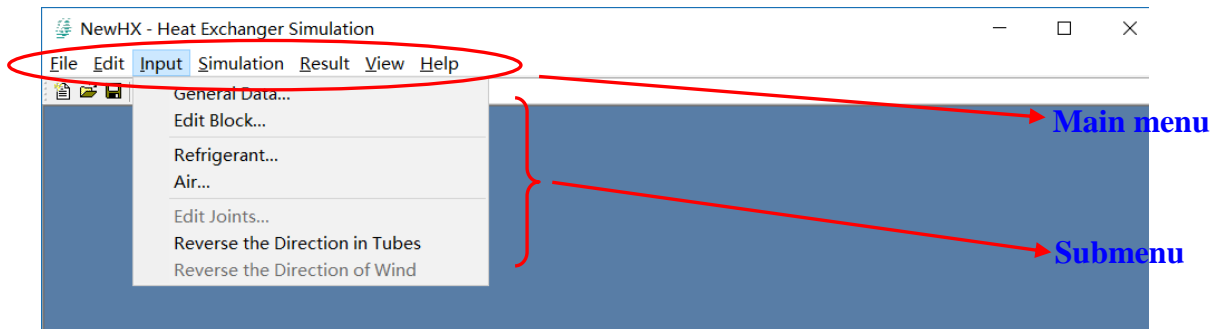
**Fig. 2-5 HXSim has been installed successfully**

### 3 Main menu

The pattern of main menu of GUI for HXSim seems as those of most Microsoft® Windows applications, with the addition of the Input, Edit, Simulation and Result sub menus. There are 7

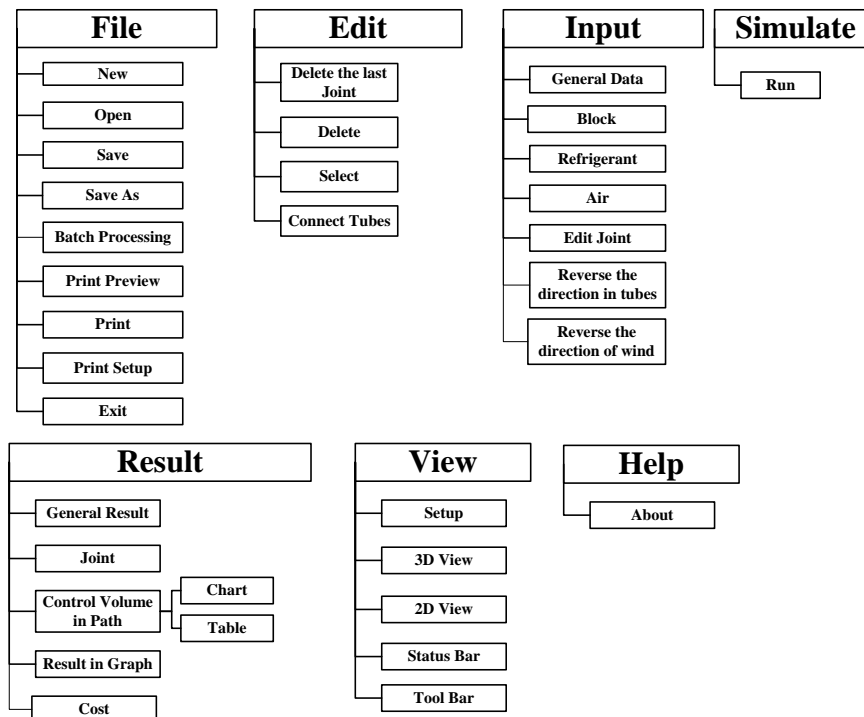


items in the main menu and each item contains several options for user to choose as shown in Fig. 3-1.



**Fig 3-1 Main menu and its submenu**

The detailed items of main menu and its submenus of HXSim are shown in Fig. 3-2.



**Fig. 3-2 Items of main menu and submenus of HXSim**

The followings are explanations of each items of main menu.

### 3.1 Submenu of File

#### 3.1.1 New

This menu item provides the access to start a new heat exchanger model. At first, users should define how many blocks the new heat exchanger has.

This menu item is always available.

### **3.1.2 Open**

This menu item provides an access to open a previous model by opening an existent disk file. The file expansion of heat exchanger is \*.hxs.

This menu item is always available.

### **3.1.3 Save**

This menu item provides an access to save the current model as a new disk file with a specified name. The file expansion of heat exchanger is \*.hxs.

If none of modification has been done after the last saving, this menu item is unavailable. If it is necessary to save the model, please select the menu item save as.

### **3.1.4 Save as**

This menu item provides an access to save the current model as a disk file of another file name. The file expansion of heat exchanger is \*.hxs.

This menu item is always available.

### **3.1.5 Batch processing**

This menu item provides an access to do batch processing.

This menu item is always available.

### **3.1.6 Print**

This menu item provides an access to print the image of heat exchanger model with printer.

This menu item is always available.

### **3.1.7 Print Preview**

This menu item provides an access to preview the image of heat exchanger model.

This menu item is always available.

### **3.1.8 Print Setup**

This menu item provides an access to setup the specified printer.

This menu item is always available.

### **3.1.9 Recent Files**

This menu item provides an access to conveniently select a recent simulation model of heat exchanger. No more than three names of latest files will be shown.

This menu item is always available.

## **3.2 Submenu of Edit**

### **3.2.1 Delete the Last Joint**

This menu item provides an access to delete the last connected joint on the heat exchanger model, so that users can cancel some joints if some mistakes have been made in connecting

manipulation.

This menu item is available only after at least one joint has been defined.

### **3.2.2 Delete**

This menu item provides an access to delete the selected paths, selected tubes, selected joints or all the joints of heat exchanger. So that all of the joints can be deleted and return to the initial state or redefine a certain path.

This menu item is available only after at least one tube existed.

### **3.2.3 Select**

Selecting this menu items can change the responded function of mouse clicking to select objects. Users can select a block, a tube, a joint, the inlet node or the outlet node. If a block is selected, it will be highlighted and can be moved by moving mouse. If a tube or a joint is selected, a path is specified as a result, and then all the tubes and joints which belong to the path will be highlighted.

This menu item is available after that a new case has established.

### **3.2.4 Connect Tubes**

Selecting this menu item can change the responded function of mouse clicking to connect tube. Users can define joints by clicking tube ends, the inlet node or the outlet node.

This menu item is available after at least one tube has been added in heat exchanger.

### **3.2.5 Copy Path(s)**

This menu item is used for efficiently duplicating circuits of the same pattern. It allows copying many circuits at the same time. Lots of efforts could be saved by correctly using this function.

This menu item is available when any circuit(s) has been selected.

## **3.3 Submenu of Input**

### **3.3.1 General Data**

This menu item provides an access to input inlet and outlet tube types of heat exchanger and block number of heat exchanger.

This menu item is available only after heat exchanger model has been established.

### **3.3.2 Block**

This menu item provides an access to edit parameters of blocks.

This menu item is available only after heat exchanger model has been established.

### **3.3.3 Refrigerant**

This menu item provides an access to input the inlet refrigerant parameters.

This menu item is available only after the model of heat exchanger has been established.

### **3.3.4 Air**

This menu item provides an access to input the inlet air parameters.

This menu item is available only after the model of heat exchanger has been established.

### **3.3.5 Edit Joints**

This menu item provides an access to edit parameters of joints.

This menu item is available only after at least one joint has been defined.

### **3.3.6 Reverse the direction in tubes**

This menu item provides an access to reverse the direction in tubes.

This menu item is available only after the model of heat exchanger has been established.

### **3.3.7 Reverse wind direction**

This menu item provides an access to reverse the direction of the wind of the selected block(s). Select a block before clicking this item so that the program can have a target (block) to perform this operation.

This menu item is available only after block has been selected.

## **3.4 Submenu of Simulate**

### **3.4.1 Run**

This menu item provides an access to perform a heat exchanger simulation using the values which have been entered before. A simulation can only be performed if all values are presented and valid. If any mistakes have been found, an error dialog window will be popped up to tell which parts are not apropos. If no error is found, the simulation program will run. In the course of simulation, the progress of the simulation will be shown in the progress window. The simulation can be interrupted at any time if needed.

## **3.5 Submenu of Result**

### **3.5.1 (New) General Result**

This menu item provides an access to see some general data results of heat exchanger simulation in form of PDF report.

Only after the simulation of heat exchanger was accomplished, this menu item is able to perform.

### **3.5.2 General Results**

This menu item provides an access to see some general data results of heat exchanger simulation.

Only after the simulation of heat exchanger was accomplished, this menu item is able to perform.

### **3.5.3 Joints**

This menu item provides an access to see the pressure drop along every joint.

Only after the simulation of heat exchanger was accomplished, this menu item is available.

### **3.5.4 Control Volumes in Path**

#### **(1) Chart**

This menu item provides an access to see both inlet and outlet state parameters of air/refrigerant in every control volume of every tube through a selected refrigerant path in charts.

#### **(2) Table**

This menu item provides an access to see both inlet and outlet state parameters of air/refrigerant in every control volume of every tube through a selected refrigerant path in a whole table.

This menu item is available only after the simulation of heat exchanger was accomplished.

### **3.5.5 Show Results in Graph**

This menu item provides an access to open the results window which shows the simulation results.

Only after the simulation of heat exchanger was accomplished, this menu item is available.

### **3.5.6 Cost**

This menu item provides an access to open the cost window which shows the heat exchanger cost.

This menu item is available after the simulation has finished.

### **3.5.7 Export Report Form**

This menu item provides an access to export the report form with printer. Before previewing the report, please capture the circuits diagram to put into the report.

This menu item is only available after the simulation has finished.

## **3.6 Submenu of View**

### **3.6.1 Setup**

This menu item provides an access to reset some characters of the main view.

This menu item is unavailable currently.

### **3.6.2 3D View**

Selecting this menu item can change the screen to show the heat exchanger model in 3-dimension style.

This menu item is always available.

### 3.6.3 2D View

Selecting this menu item can change the screen to show the heat exchanger model in 2-dimension display mode.

This menu item is always available.

## 4 Menu in result window

The menu in result window includes two items that are File and view. The items of menu in result window are shown in Fig. 4-1.

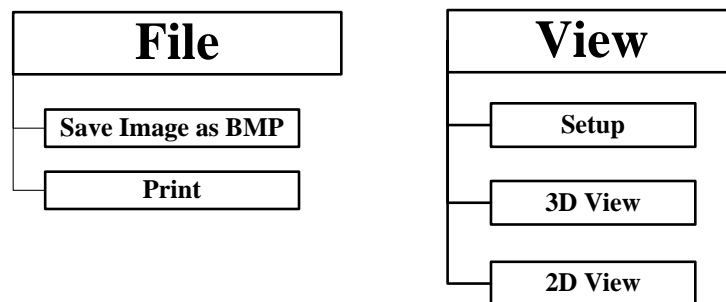


Fig. 4-1 Items of menu in result window

### 4.1 Submenu of File

#### 4.1.1 Save image as BMP

This menu item provides an access to save the image of results graph as BMP file.

This menu item is always available.

#### 4.1.2 Print

This menu item provides an access to print the image of results graph of heat exchanger model with printer.

This menu item is always available.

### 4.2 Submenu of View

#### 4.2.1 Setup

This menu item provides an access to reset the parameter of refrigerant which is shown in result window.

This menu is always available.

#### 4.2.2 3D View

Selecting this menu item can change the screen to show the results graph in 3-dimension style.

This menu item is always available.

### 4.2.3 2D View

Selecting this menu item can change the screen to show the results graph in 2-dimension display mode.

This menu item is always available.

## 5 Toolbar

Toolbar provides a convenient way to select some functions. The main window contains a toolbar whose functions are shown as below. Each of the buttons will perform the same function as the menu item with the same name. And the state of a button is also change following the state of the relevant menu item.

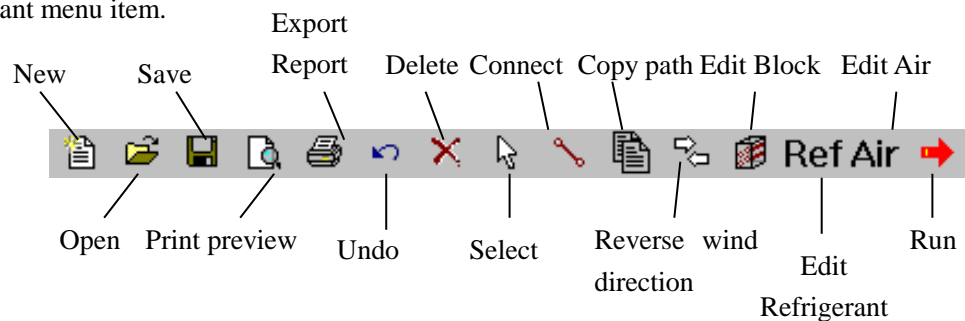


Fig. 5-1 Function of toolbar

## 6 Data input windows

The details of block, tubes, fins, refrigerant and airflow are entered on data input dialog windows. Click Ok button can check the values and close the window. Warning dialog would show if some edit box is not inputted apropos. The following will introduce each data input window in detail.

### 6.1 General data input window

When the menu item **Input | General data** is selected, the general data dialog will be popped up as shown in Fig 6-1. In this dialog, users can add block number.

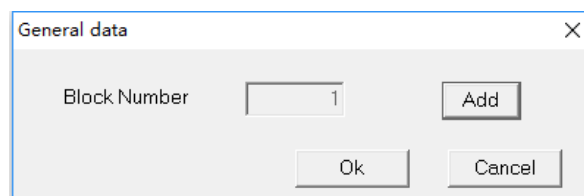
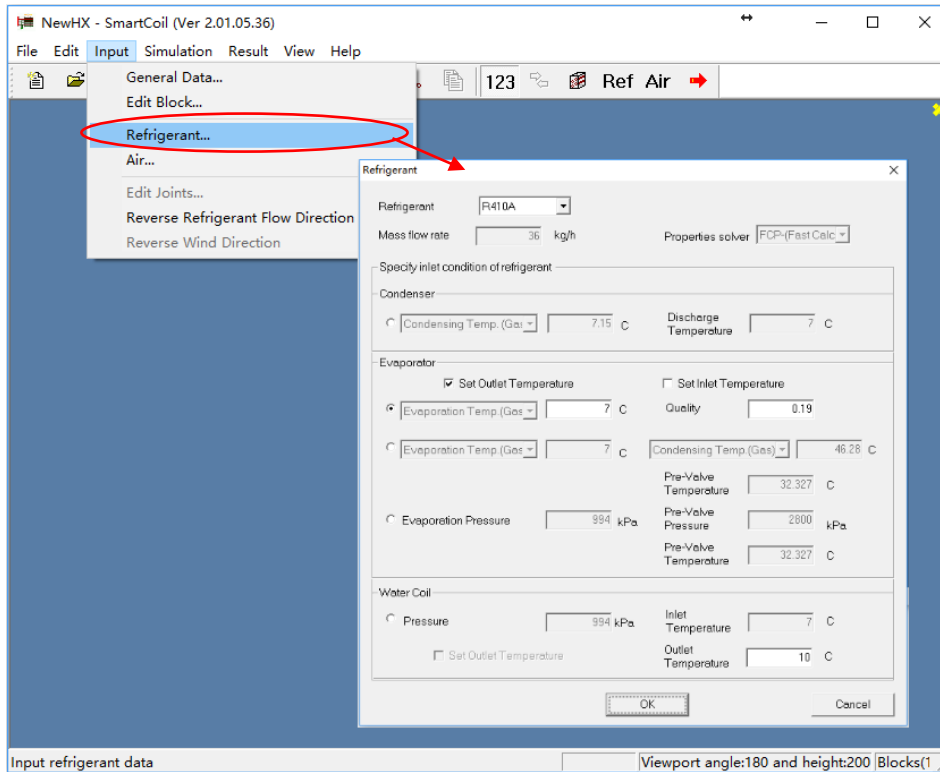


Fig. 6-1 General data dialog after clicking on the menu item **Input | General data**

### 6.2 Refrigerant status input window

In the refrigerant status input window, users should select the appropriate refrigerant from the

drop-down list provided. The available refrigerant includes R134a, R22, R410A, R290, R32, R404A, R407C, water and CO<sub>2</sub>. And then input mass flow rate, and the inlet thermodynamic properties of refrigerant such as inlet pressure and enthalpy. The refrigerant dialog is shown in Fig. 6-2.



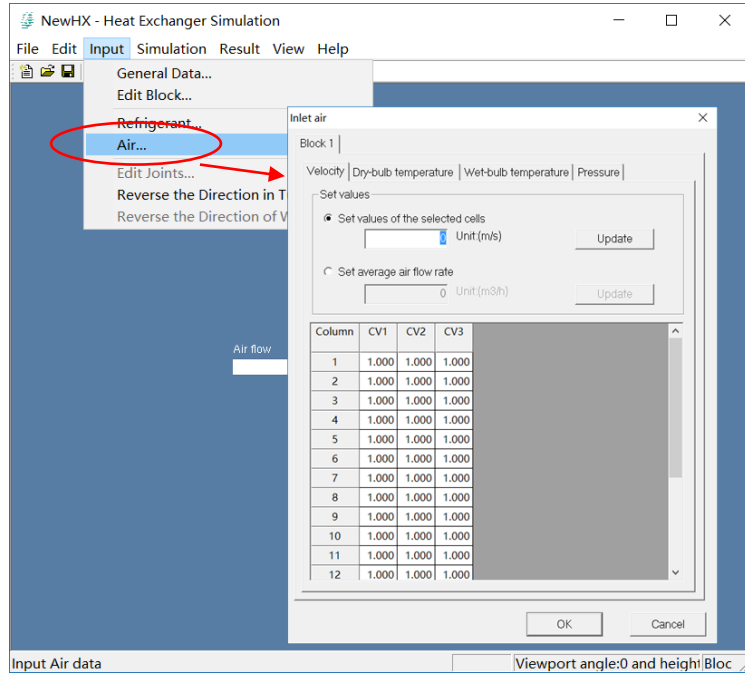
**Fig. 6-2 Refrigerant dialog**

### 6.3 Inlet airflow input window

In air input window, users can enter inlet airflow velocity (m/s), dry bulb temperature (°C), relative humidity (%), and pressure (kPa) of each control volume. And for each parameter, there are two options, which are “Average value” and “specific distribution”, as shown in Fig. 6-3.

- (1) If the option “Average value” is selected, users can set the average value of the parameters in edit box.
- (2) If the option “Specify value” is selected, users can input value of each control volume. On the left top of the window, there are edit box and a button named “Update”. After the button “Update” is clicked, the data of cells that have been selected and highlighted will change to the new values.

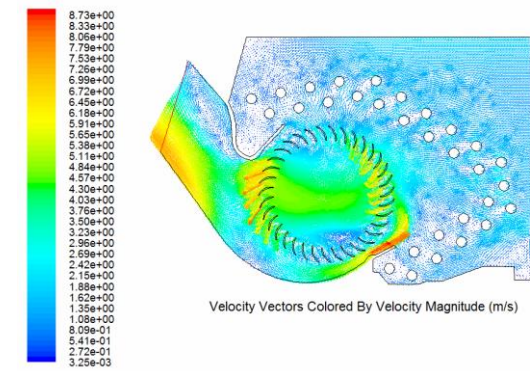




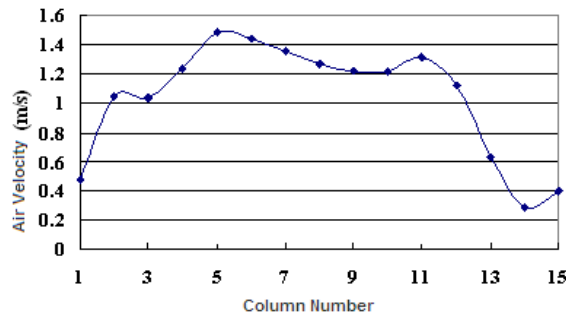
**Fig. 6-3 Inlet air input window**

When users input air velocity of inlet, different typed units have different air velocity distributions.

For the evaporator of air-conditioner hanging machine, the distribution of inlet air is shown in Fig.6-4. According to Fig.6-5, air velocity in the bottom part and in the top part is small, while it is much larger in the middle part of the heat exchanger.



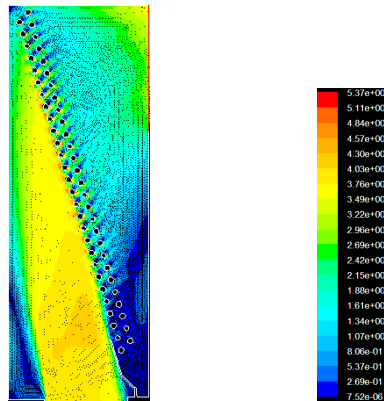
(a)



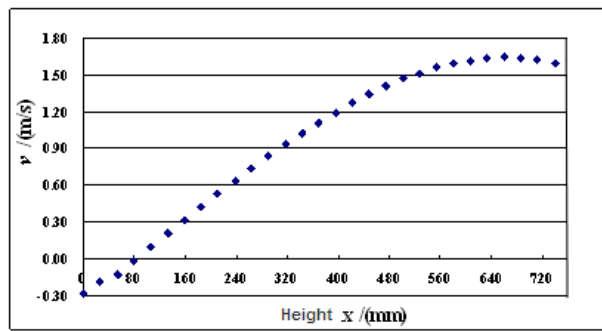
(b)

**Fig.6-4 Air velocity distribution of the evaporator of cabinet air-conditioner**

For the evaporator of cabinet air-conditioner, the distribution of inlet air is shown in Fig.6-5. According to Fig.6-6, air velocity in the bottom part is small, while it is much larger in the top part of the heat exchanger.



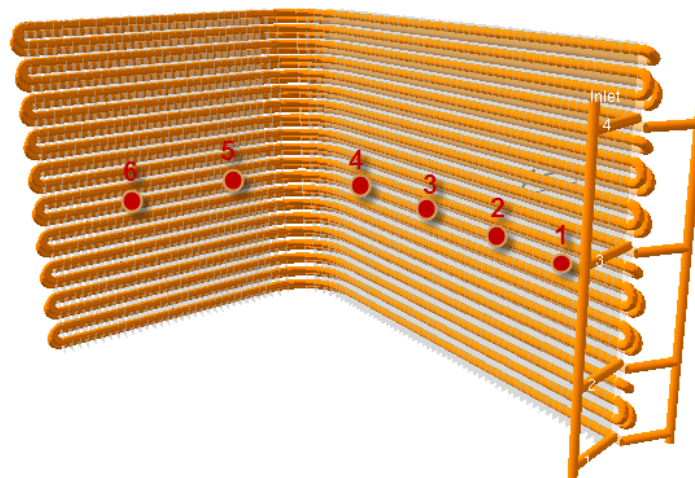
(a)



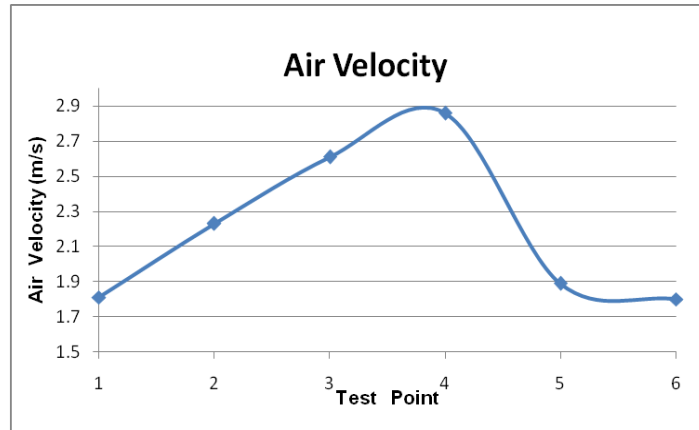
(b)

**Fig.6-5 Air velocity distribution of the evaporator of cabinet air-conditioner**

For the L typed condenser of air-conditioner, the distribution of inlet air is shown in Fig.6-6. According to Fig.6-6, air velocity in the front part and in the back side is small, while it is much larger in the middle part of the heat exchanger.



(a)

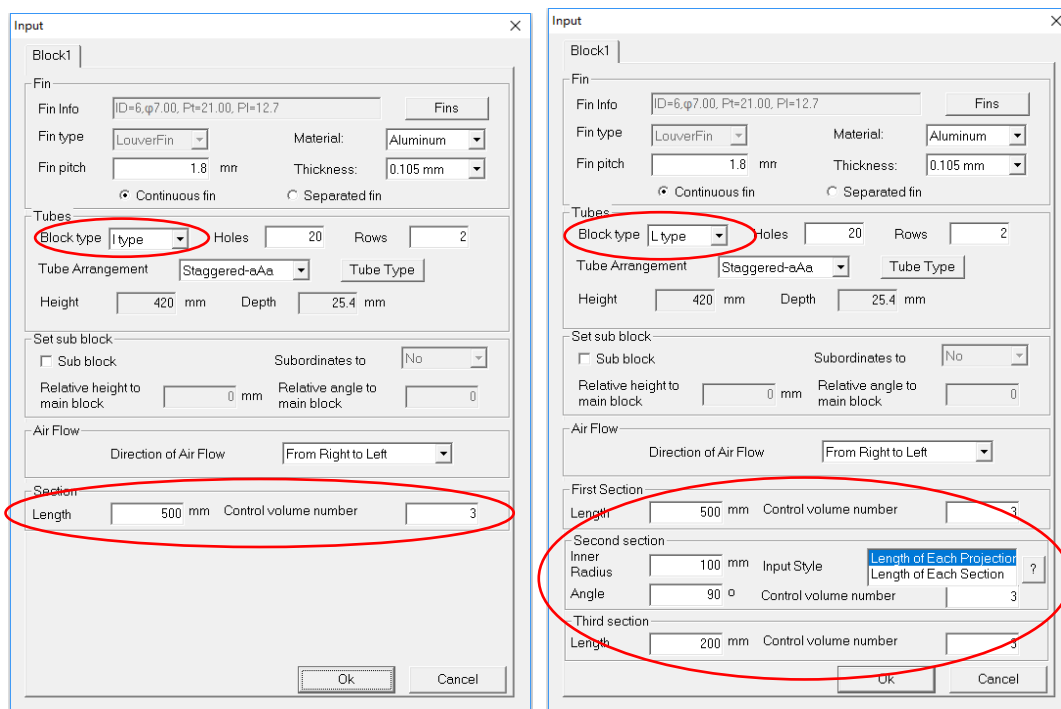


(b)

Fig.6-6 Air velocity distribution of the evaporator of cabinet air-conditioner

### 6.4 Heat exchanger dimension input window

In dimension input window for HXSim, user can input structural parameters and fin type. And the edit and button in this window are explained in detailed as the followings.



(a) I type

(b) L type

Fig. 6-7 heat exchanger dimension input window

#### (1) Introduction of edit

The detailed meanings of edits in the dimension input window are shown in Table 6-1. In these edits, the “Row number” is most important in all the input parameters. Only after inputting the row number, the column number of each row and tubes in each column can be defined.

**Table 6-1 Introduction of edit**

Parameter	Unit	Remark
Block type		HXSim can simulate I type, L type and C type HX.
Rows number		
Depth	mm	Depth of fin-and-tube heat exchanger
Height	mm	Height of heat exchanger
Length	mm	Length of heat exchanger
Ambient Temperature	C	Ambient temperature
Fin type		It will be automatically inputted by clicking button “Fins”
Fin pitch	mm	For variable fin pitch, please click button “specify”
Fin name		The name of the fin of the block
Continuous fins		Whether the fins are continuous planes or separated as bands
Control volume number		Max number is 10

**(2) Introduction of button**

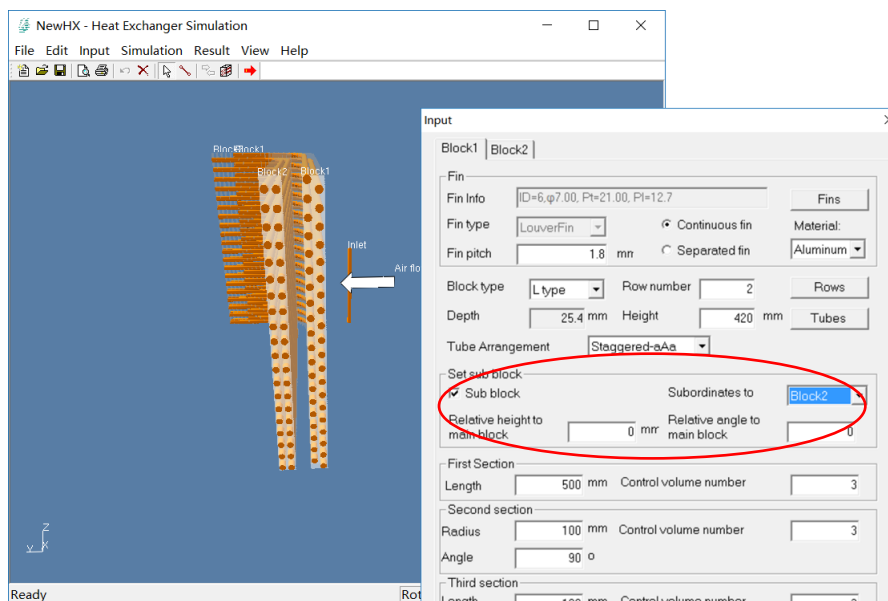
The buttons occurred in dimension input window are shown in Table 6-2.

**Table 6-2 Introduction of button**

Button	Function	Reference
TubeType button	Users can open Tubes database to select different tubes.	In section 6.5
Fin button	Users can open Fin database to select different fins.	In section 6.6

**(3) Introduction of sub block**

When users define multi-block HX, if the wind flow through Block A and then flow through Block B, users need to set Block A as sub block as shown in Fig.6-8.



**Fig.6-8 Set sub block**

### (1) Column number

Each row contains number of tubes.

### (2) Row space

Row space is defined as the space between the centerlines of current tube row and the tube row before. For the first row, the row space is defined as the space from centerline of current tube row to the left boundary of fin-and-tube heat exchanger.

At most times, there's no need to edit it. It's default value changes according to the current fin.

## 6.5 Tube structure input window

The tube structure input window in SmaricCoil is as shown in Fig. 6-10.

The description of tube contains three parts, name, tube type (smooth or grooved) and column space.

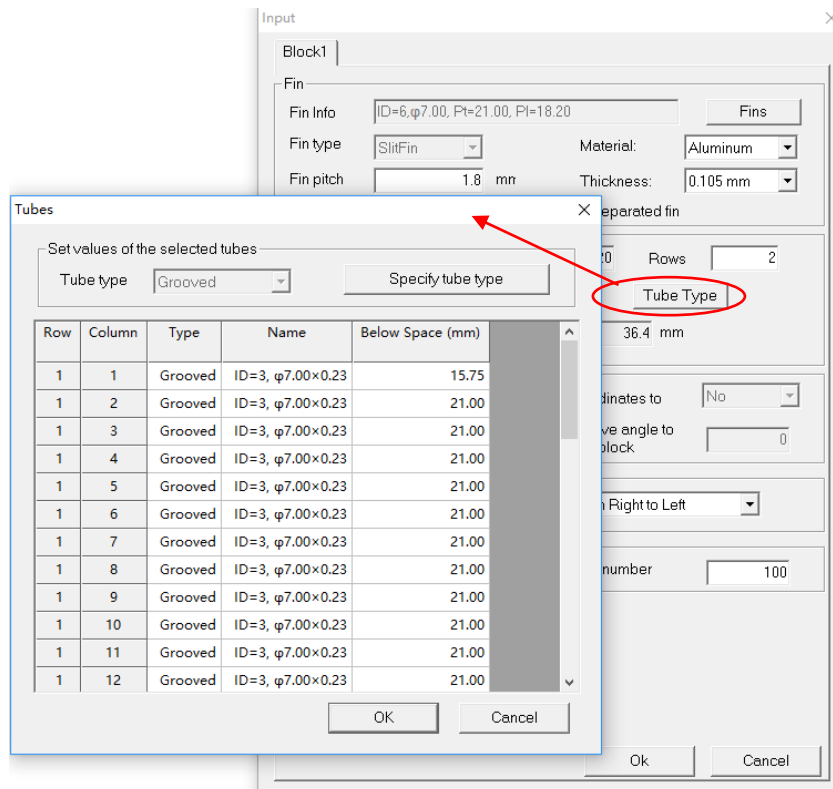
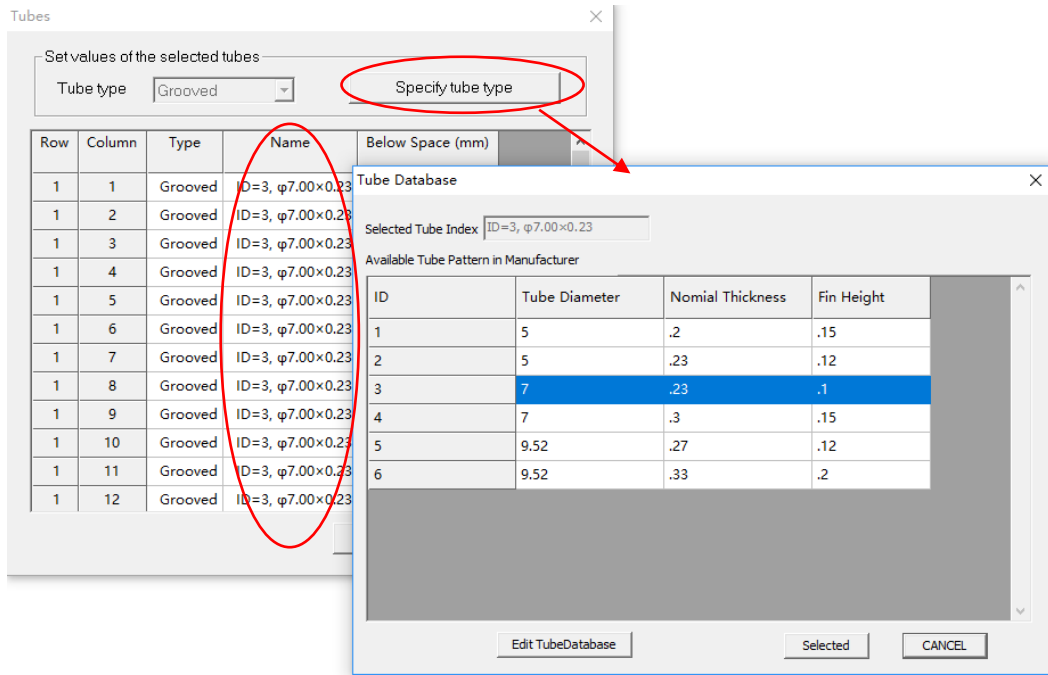


Fig. 6-10 Tube structure input window

### 6.5.1 Tube type

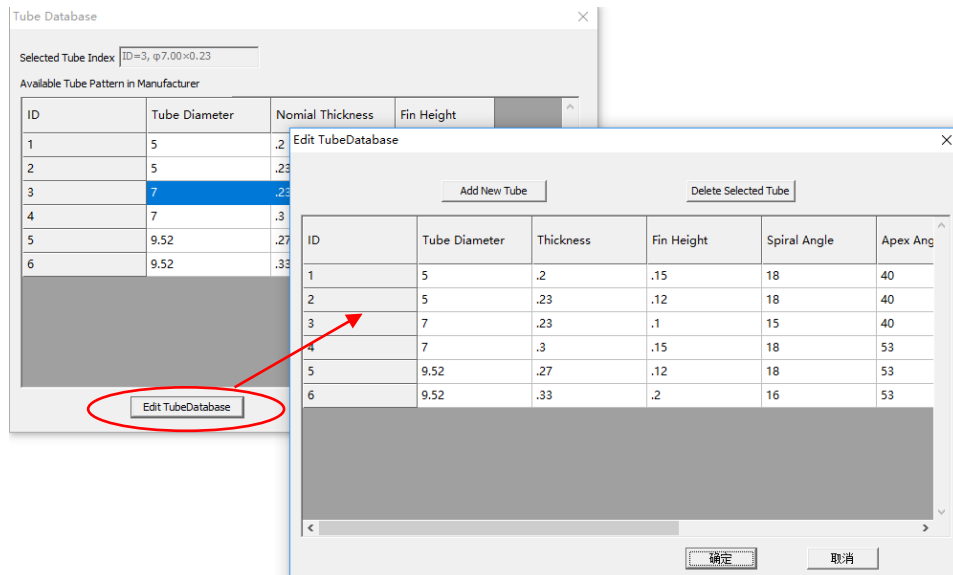
Tube type includes smooth tube and enhanced tube type. Users can select existed tube from database. One thing to notice, tubes with 0mm fin height means that it's smooth tube. Otherwise it's enhanced tube.



**Fig.6-11 Load tube type information from database**

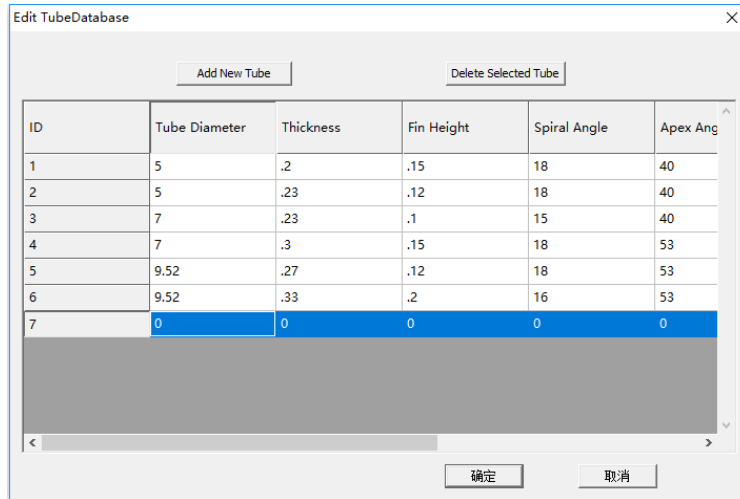
### 6.5.2 Edit Tube Database

In the tube database window, click “Edit TubeDatabase” button to modify tube database. Users can add new types of tubes to the tube database, delete the existed tubes in database.



**Fig.6-12 Modify tube database**

Click “Add New Tube” to add new types of tube to tube database. Users can input tube parameters directly in the database, as shown in Fig.6-3.



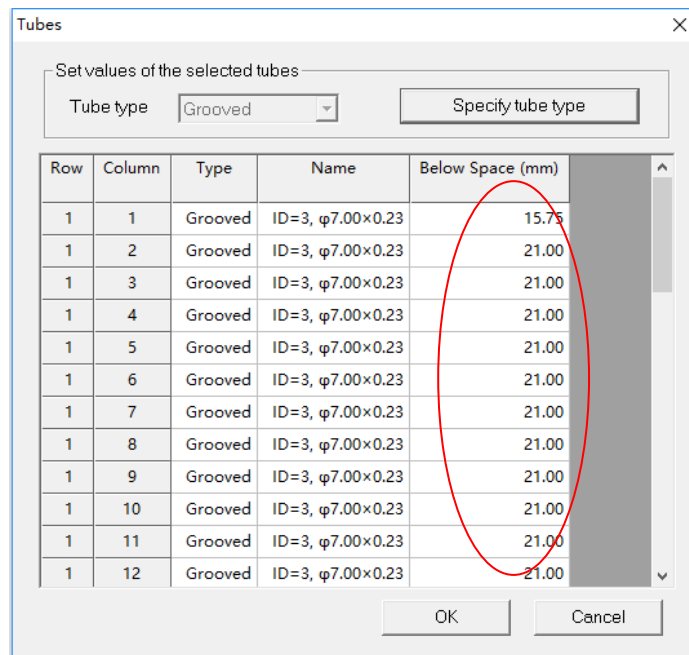
**Fig.6-13 add new types of tube**

Select the tube and click “Delete Selected Tube” to delete the existed tubes in the databae.

### 6.5.3 Column space

For now, column space can be conveniently set by select “tube arrangement” in Block dialog. **If it is not “Custom” tube arrangement, column spaces cannot be edited.**

Column space is defined as the space between the centerline of a tube and the tube just below. For the lowest tube, the column space is defined as the space from the center of the tube to the bottom of heat exchanger. User can modify values of column space in the chart directly.



**Fig. 6-14 Column space setting**

## 6.6 Fin type input window

### 6.6.1 Fin type input

In order to manage the fin data conveniently for user, the database is introduced into the dialog. After clicking the button “Fins”, the database dialog will pop out. Select one of the fins by double clicking the target item or clicking “selected”.

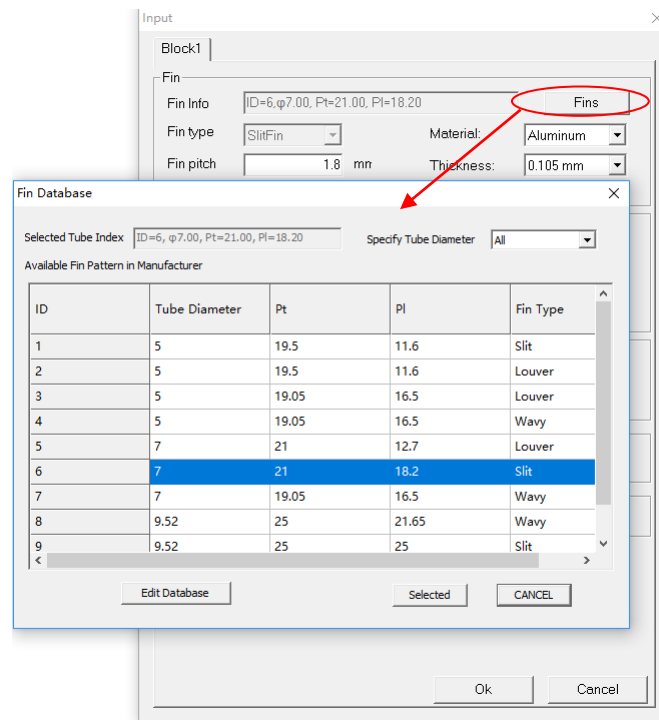
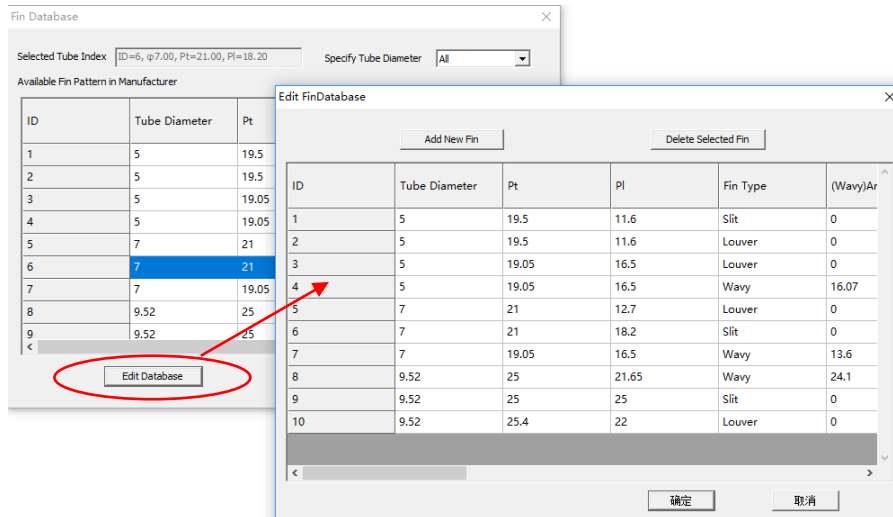


Fig. 6-15 Fin type window

### 6.6.2 Edit Fin Database

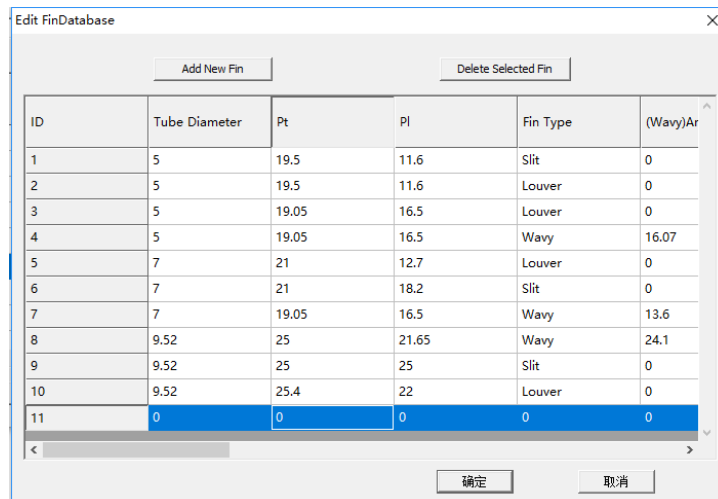
In the fin database dialog, click “Edit Database” button to modify fin database. Users can add new types of fins to the fin database, delete the existed fins in database.





**Fig.6-16 Modify tube database**

Click “Add New Fin” to add new types of Fins to fin database. Users can input fin parameters directly in the database, as shown in Fig.6-17.

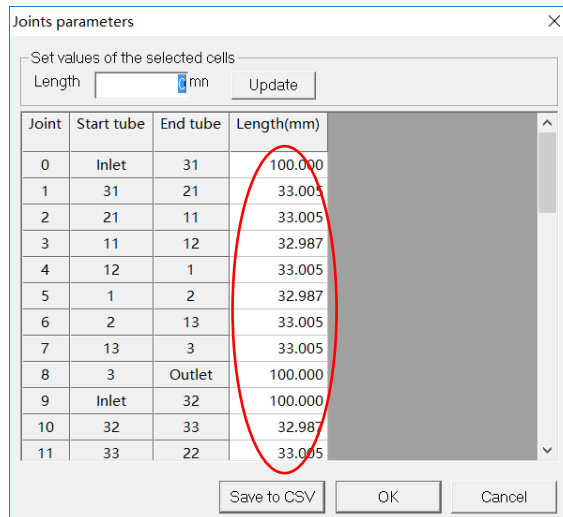


**Fig.6-17 add new types of tube**

Select the fin and click “Delete Selected Fin” to delete the existed fin in the database.

## 6.7 Joint input window

For the joint input window, there are an edit box of joint length and a button “Update” on the right top of the window. User can input joint length in the edit box. After the button “Update” is clicked, the values of cells which are selected by user can be updated. In addition, user also can input data into grid cell to update the value of the cell. And when initialing the dialog, the joint tube length will be calculated automatically.



**Fig. 6-18 Joint window**

## 7 Connect Tubes

The main window shows the heat exchanger model in 3-dimension scene or as 2-dimension sketch.

In 3-dimension display mode, the heat exchanger can be shown realistically.

In 2-dimension display mode, the two end sides of heat exchanger are the most importance. The length and the profile of block have not been considered.

This chapter will explain how to connect tube in 3-dimension display mode and 2- dimension display mode in detail.

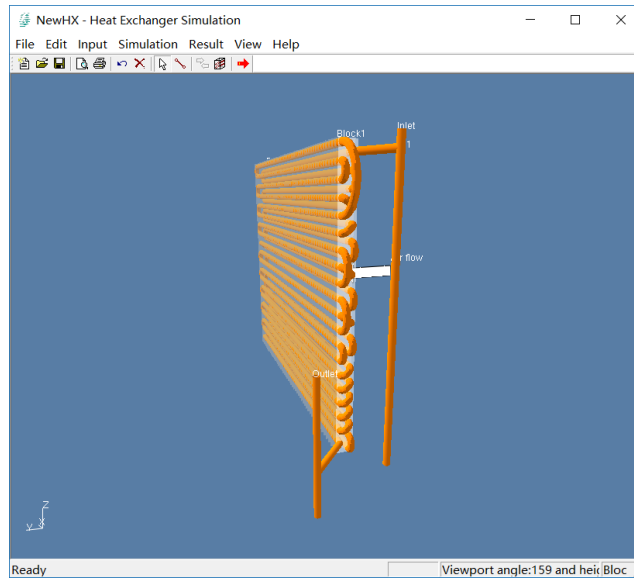
### 7.1 How to connect tubes

#### 7.1.1 Block, tubes and joints in 3-D & 2-D display mode

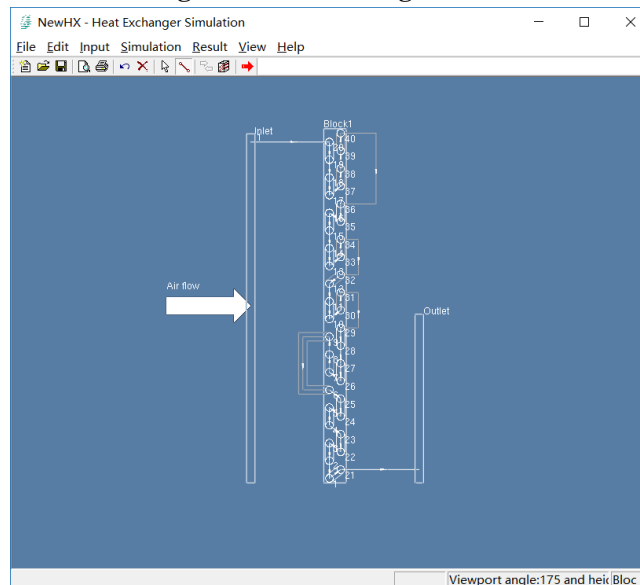
On this image, all the blocks, tubes, and joints are represented as simple figure.

In 3-dimension, the wire cuboids represent blocks of heat exchanger, the bronzy long cylinders represent tubes, and the bronzy long cylinders or half torus between the ends of tubes represent joints. The inlet node and outlet node are also showed as bronzy long cylinders. (See Fig.7-1)

In 2-dimension, the white rectangles represent blocks and the white cirques represent the near ends of tubes. The white long straight lines or parallels between the ends of tubes represent joints. The inlet node and outlet node are showed as white long rectangles. (See Fig.7-2)



**Fig. 7-1 Heat exchanger in 3D view**



**Fig. 7-2 Heat exchanger in 2D view**

### 7.1.2 Position of block, tubes and joints

This image can show the heat exchanger model in 3-dimension or 2-dimension.

#### **3-dimension:**

There is a little coordinate at the left bottom corner of screen in 3-dimension. The inlet air flow is placed along Z-axis below the heat exchanger. The vertical direction is along the Z-axis and the horizontal plane is defined by the X-axis and Y-axis. The heat exchanger block is placed in the natural way. The tubes are placed along the X-axis. The inlet and outlet tubes are placed along Z direction. (See Fig. 7-1)

#### **2-dimension:**

In 2-dimension, the direction of inlet airflow is also fixed as from the bottom side of a block to the top side. The high direction is along the vertical direction. Although the directions are fixed, the blocks can change their relative position by moving mouse. The inlet node and outlet node can

also be translated. The image can zoom in or zoom out. (See Fig.7-2)

### 7.1.3 Mouse clicking status

The operation of clicking left button of mouse is defined as two meanings, namely select and connect.

#### **Select:**

If the menu item **Edit | Select** is specified, clicking mouse can select blocks, tubes, joints inlet node and outlet node, but cannot connect tubes.

#### **Connect:**

If the menu item **Edit | Connect tubes** is specified, clicking mouse can select ends of tubes, inlet node and outlet node, so as to connect tubes.

### 7.1.4 Mouse moving status

The operation of moving mouse is defined as three different meanings, namely translate, rotate and zoom in/out.

#### **Translate:**

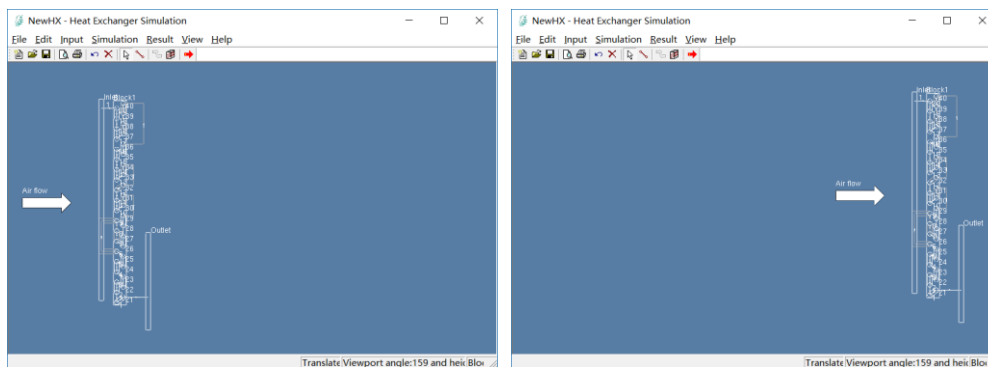
In both 2-dimension and 3-dimension view, if pressing the left button of mouse, and moving mouse can translate all objects or one certain object, just as shown in Fig.7-3 and Fig.7-4.

#### **Rotate:**

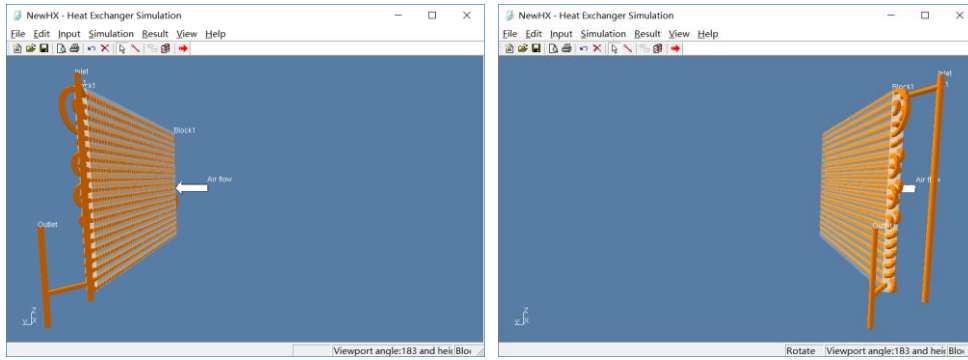
In 3-dimension view, if pressing the key “Ctrl” in the keyboard and moving mouse can rotate all objects or one certain object, just as shown in Fig.7-5.

#### **Zoom in/out**

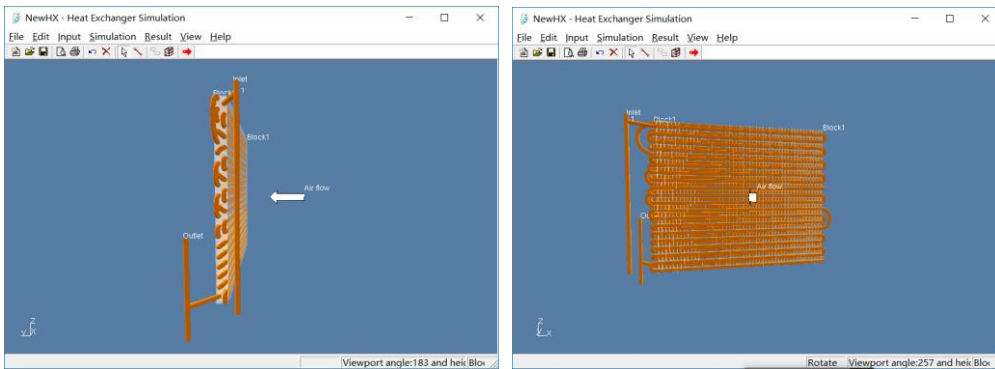
In both 2-dimension and 3-dimension view, if rolling the middle button of mouse, which is the wheel of mouse can zoom in or zoom out all objects in the main view, just as shown in Fig.7-6 and Fig.7-7.



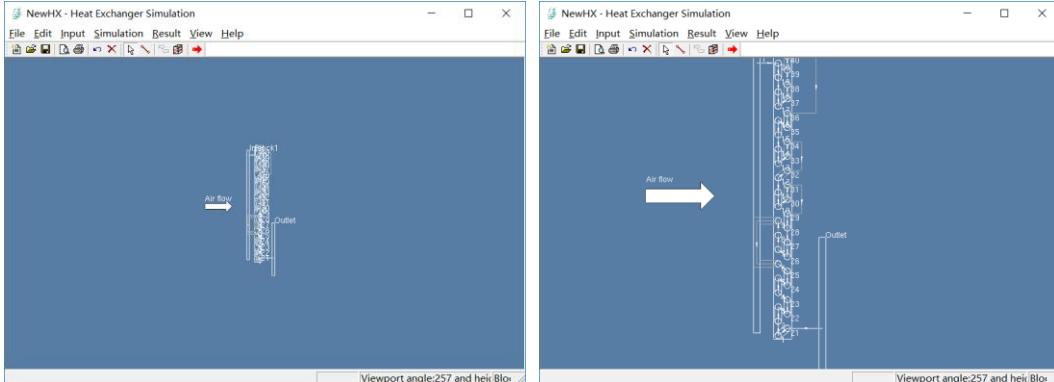
**Fig. 7-3 Translate the Object in 2-dimension view**



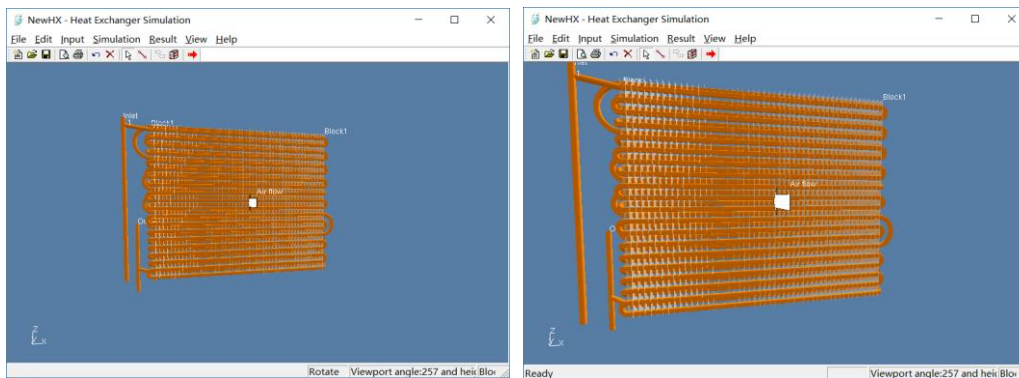
**Fig. 7-4 Translate the Object in 3-dimension view**



**Fig. 7-5 Rotate the heat exchanger (3D)**



**Fig. 7-6 Zoom in heat exchanger (2D)**



**Fig. 7-7 Zoom in heat exchanger (3D)**

### 7.1.5 Select object

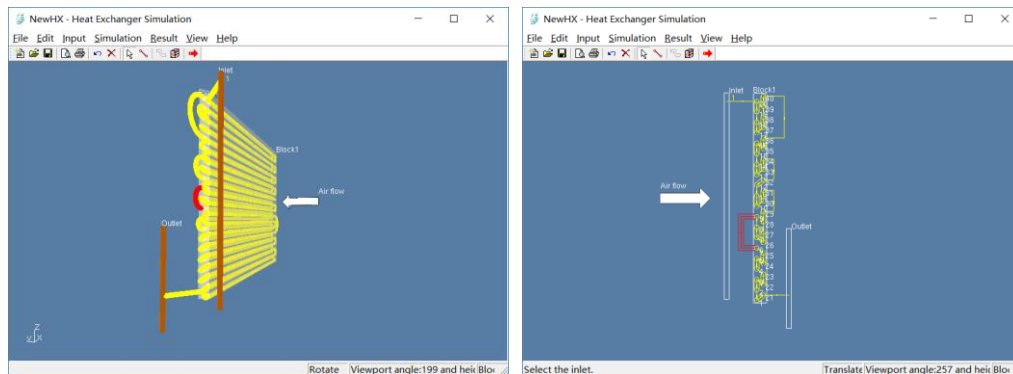
In both 3-dimension and 2-dimension, nearly every object shown on screen can be selected by clicking the left button of mouse, such as tubes, joints, inlet and outlet. The range of objects can be selected depending on mouse clicking state.

If a tube or joint is selected, a path will be specified, so all the tubes and joints in this path will be highlighted in yellow color and the selected tube will be highlighted in red color.

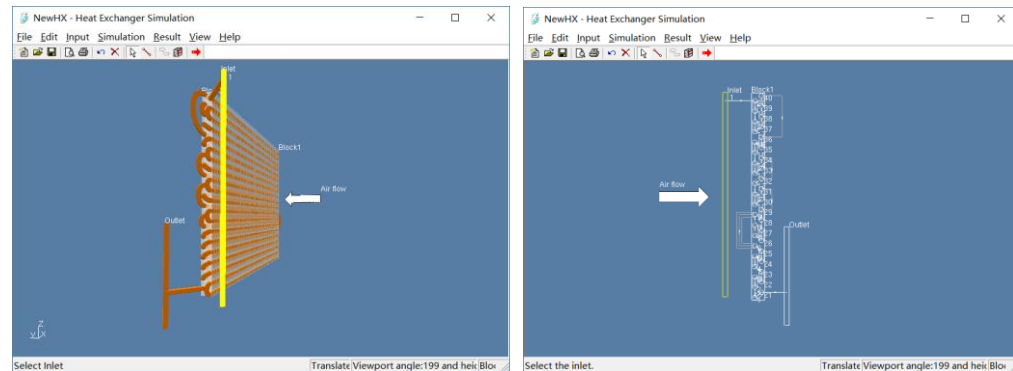
If the inlet node or the outlet node is selected, the node will be highlighted, too. Then users can translate this node by moving mouse.

Clicking the right mouse will cancel the choice before.

If tube or joint is selected, all the objects will be translated or rotated at the same time by moving mouse. On the other way round, if the inlet node or the outlet node is selected, only the specified object will be moved by moving the mouse.



**Fig. 7-8 A path has been selected (3D and 2D)**



**Fig. 7-9 Inlet tube has been selected (3D and 2D)**

### 7.1.6 Shortcut keys

Some shortcut keys are defined to perform the same functions as moving mouse to move objects.

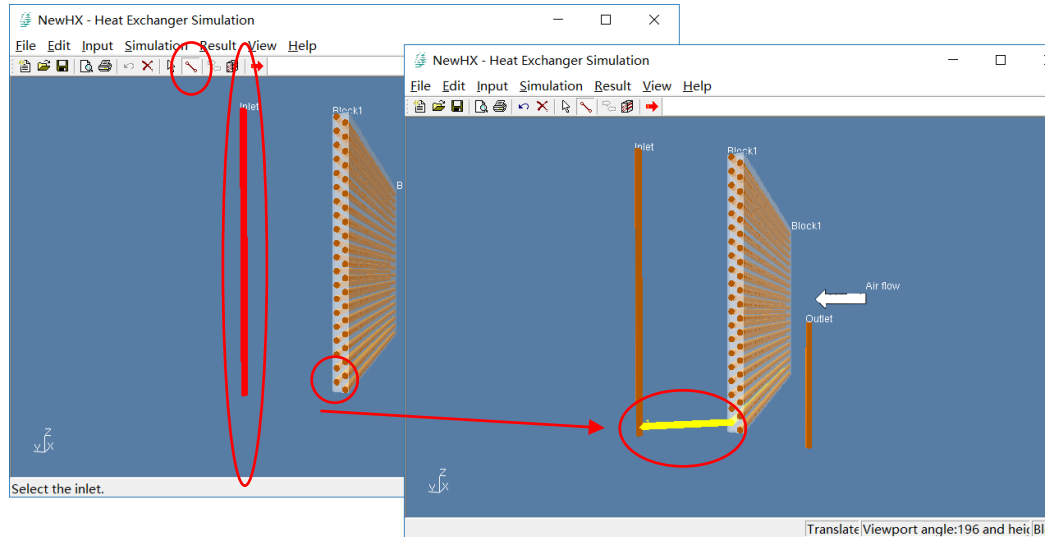
In 3-dimensin, pressing the Space key can rotate all objects with 180°, so users can see the other side of block very rapidly.

### 7.1.7 Connect tubes

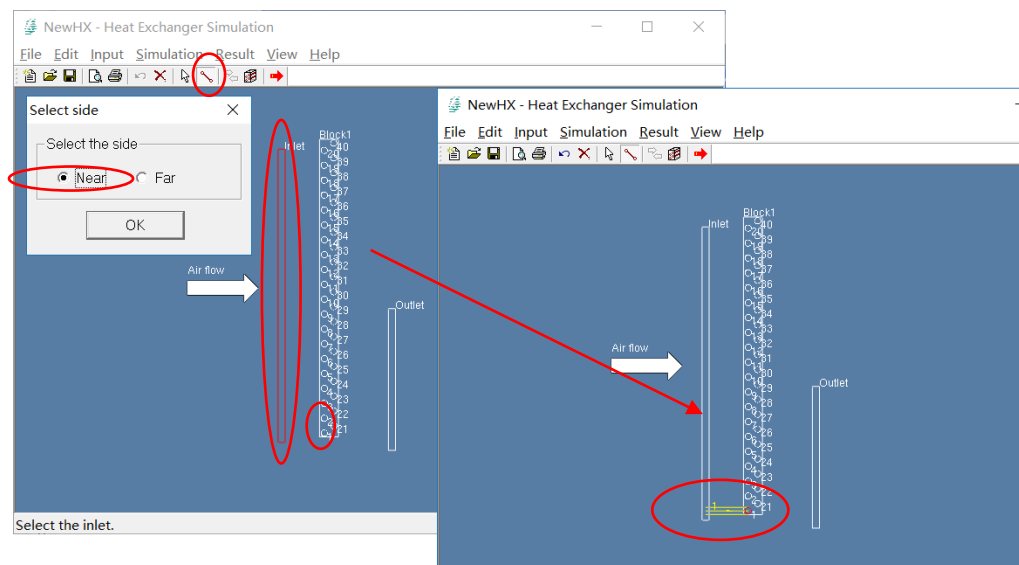
As mentioned before, either end of a tube can be selected by clicking the left button of mouse. The inlet node and the outlet node can be selected, too. If users want to specify this end as the

beginning of a joint, this end will be highlighted in red. Then select an end of another tube, if this selection is valid to define a joint, a new joint will show at once.

In 2-dimension, when an end of a tube is selected, the near side or far side is not definite, software will deduce the side location basing on the joints connected before. If the side location cannot be deduced, a window will be popped up to get a reply to specify the side location.



**Fig.7-10 The first steps to connect tubes in 3-D**



**Fig.7-11 The first steps to connect tubes in 2-D**

### 7.1.8 Delete tube or path

After clicking the menu item **Edit | Delete**, the Delete window will be shown. There are three modes for deleting which are deleting all joints, deleting joints, deleting tubes. The following will explain these three modes in detail.

#### (1)Deleting all joints

If nothing has been selected in window, after clicking the menu item **Edit | Delete**, the deleting window will be shown. In the deleting window, only one option can be chosen which is “Delete all joints” as shown in Fig. 7-12. If clicking button “OK”, all the joints that have been

connected will be deleted.

### (2)Deleting joints

If a joint has been selected in window, after clicking the menu item **Edit | Delete**, the deleting window will be shown. In the deleting window, there are four options can be chosen:

#### a. All joints in all paths

This function is the same as the function of deleting all joints which have been discussed above.

#### b. The selected joint

This function is used to delete the selected joint.

#### c. The selected joint and the following

This function is used to delete the selected joint and the following joints, just as Fig. 7-13.

### (3)Deleting Tubes

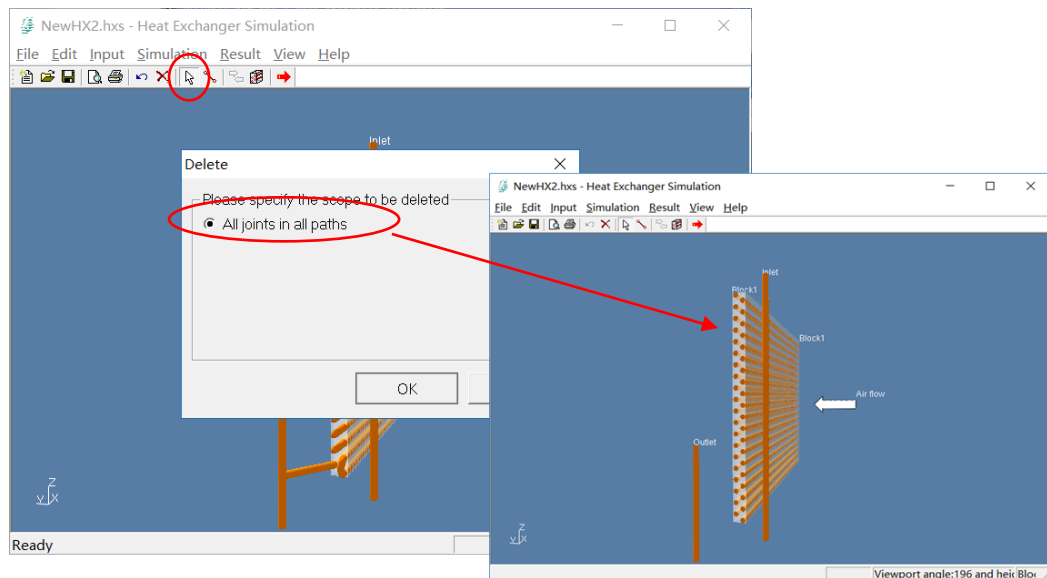
If a tube has been selected in window, after clicking the menu item **Edit | Delete**, the deleting window will be shown. In the deleting window, there are four options can be chosen:

#### a. All joints in all path

This function is the same as the function of deleting all joints which have been discussed above.

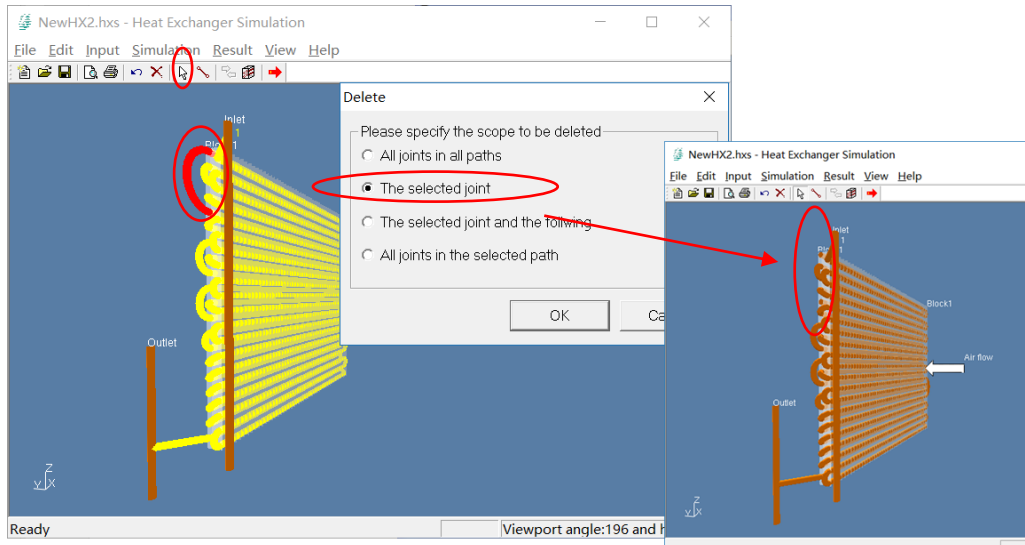
#### b. The selected tube

This function is used to delete the selected tube, just as Fig.7-14.

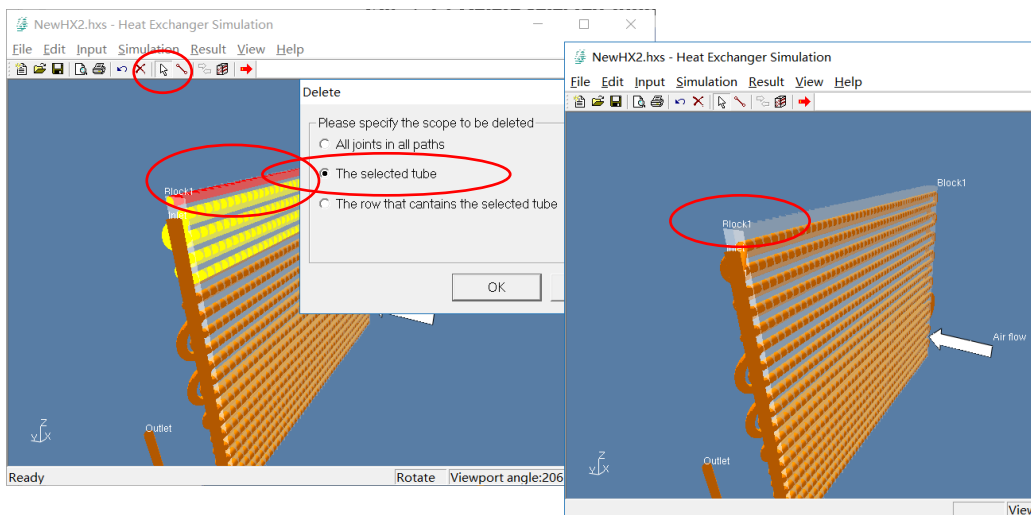


**Fig. 7-12 Delete all tube joints**





**Fig. 7-13 Delete selected joint and the following**



**Fig. 7-14 Delete selected tube**

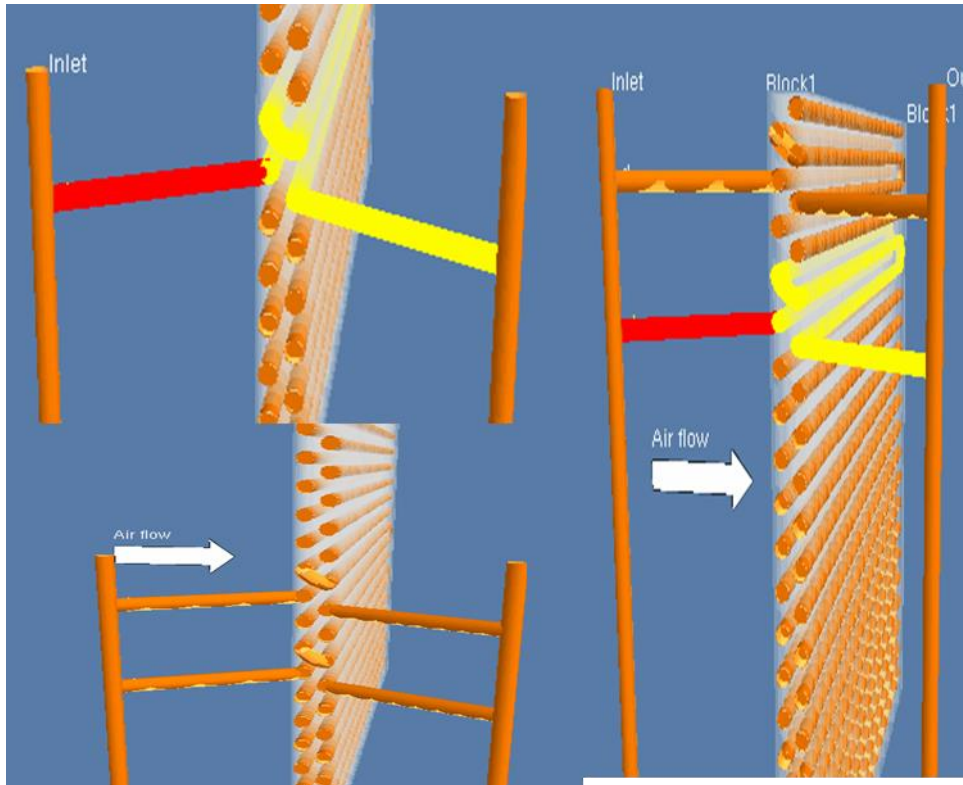
## 7.2 Copy selected paths

This function allows users to efficiently duplicate circuits of the same pattern. It allows copying many circuits at the same time. Lots of efforts could be saved by correctly using this function.

One thing to notice, for now the position of copied path(s) is not selectable. They are put right above the original path(s), which means it is important to make sure there are enough tubes above to perform copying and they are not occupied before.

First, select path(s) to be copied. Then, click “Copy Path”. If there are enough tubes and they are not occupied, copied path(s) would appear on top of the original path(s).

This menu item is available when any circuit(s) has been selected.

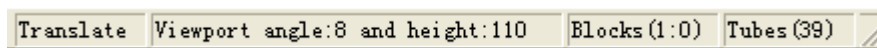


**Fig. 7-15 Copying Selected Path**

### 7.3 Status bar

The function of status bar is to show some information of main view of heat exchanger, and will be introduced hereinafter.

There are five panes in the status bar. The 1<sup>st</sup> pane shows some hints of the menu item, notes of connection, etc. The 2<sup>nd</sup> pane shows the view point. The 3<sup>th</sup> pane shows the block number and the 4<sup>th</sup> pane shows the number of tube.



**Fig. 7-16 Status bar**

## 8 Run a simulation

### 8.1 Run a simulation

#### 8.1.1 Running a simulation

Once all data has been entered and validated, simulation will run after selecting the **Simulation | Run** menu item. Simulation program is performed using the latest design.

#### 8.1.2 Progress dialog window

Once a simulation is underway, the progress window will be popped out. In this window, a

label shows the time that the simulation has cost. In this window there is also a button named “Pause” which allows users to interrupt the simulation at any time.

### 8.1.3 Pause dialog window

If users click the “Pause” button, the simulation pauses at once and a pause window appears. In the Pause window, there are three buttons named “Save”, “Cancel”, and “Exit”. The detailed means of these three buttons are introduced as follows:

**(1) Save**

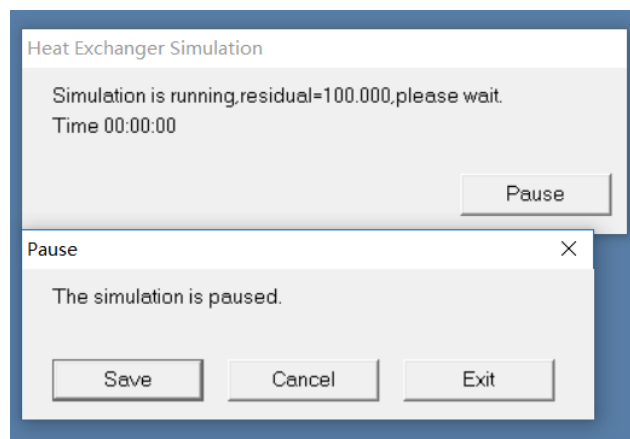
The “Save” button allows users to save the data at an optional disk file.

**(2) Cancel**

If users click the “Cancel” button, the pause window disappeared and the simulation continues to run.

**(3) Exit**

If users click the “Exit” button, the simulation will stop. Since users may click this button accidentally, the software will give users a more notice. If this decision is confirmed by user, the simulation will stop immediately.



**Fig.8-1 Progress dialog window and Pause dialog window**

If the simulation process has been completed successfully, the sub menu items below the menu item “Result” are accessible.

## 8.2 Exception handling

If user hasn't input all parameters that the simulator needs or input parameters are not correct, the exception window will be popped up and the simulation process will be terminated.

## 9 Simulation results output windows

Users can view the results of the simulation on the results windows. These windows present a textual or grid representation of the simulation output. Additionally, the tubes and joints can be shown in colors gradation to represent the change of some parameters of refrigerant along flow

path.

## 9.1 (New) General results

Select menu item **Result | (New)General Results**, (New)General result window will show. This window contains some groups of general results of the heat exchanger such as structure parameters of coil side, thermodynamic properties of outlet air and refrigerant. The window of general result is shown as Fig. 9-1.

Simulation Results			
Click "Print Results" to print the results. Double click a cell to edit it.			
Customer			
Date			
Project			
COIL SIDE			
Fin Type	Louver	Utilized Tubes	9
Fin Material	Aluminum	Non Utilized Tubes	31
Fin Spacing [mm]	1.80	Circuits	1
Fin Thickness [mm]	0.105	Tubes Per Circuit	9.00
Tube Type	Grooved	Coil Length [mm]	500.00
Tube Material	Copper	Coil Depth [mm]	25.40
Tube Dimension [mm]	7.00*0.28*0.10	Coil Height [mm]	420.00
Holes	20	Outer Area [m2]	1.227
Rows	2	Inner Area [m2]	0.091
Tube Vertical Space [mm]	21.00	Coil Face Area [m2]	0.21
Tube Horizontal Space [mm]	12.70	Inner Volume [L]	0.147
Distributor [mm]	9.5	Header Out [mm]	9.5
AIR SIDE		REFRIGERANT SIDE	
Air Inlet DB. Temp. [°C]	27.0	Refrigerant	R410A
Relative Humidity %	47.0	Evaporator Temp [°C]	7.007
Air Outlet DB. Temp. [°C]	23.4	Superheating [°C]	0.000
Relative Humidity %	54.9	Quality / Mass Fraction	0.188
Air Flow [m3/h]	749.6	Mass Flow [kg/h]	36.0
Air Mass Flow [kg/h]	962.8	Coil Pressure Drop [kPa]	7.877
Frontal Velocity [m/s]	1.0	Outlet Pressure [kPa]	989.688
Air Pressure Drop [Pa]	4.1	Ref. Charge [kg]	0.03
Atmospheric Pressure [kPa]	101.3	Ref. Side H.T.C. [W/m2*K]	5623.211
Air Side H.T.C. [W/m2*K]	118.963		

**Fig. 9-1 (New)General simulation results**

## 9.2 General results window

Select menu item **Result | General Results**, General result window will show. This window contains some groups of general results of the heat exchanger such as heat exchange capacity of refrigerant side and air side, thermodynamic properties of outlet air and refrigerant. The window of general result is shown as Fig. 9-2.

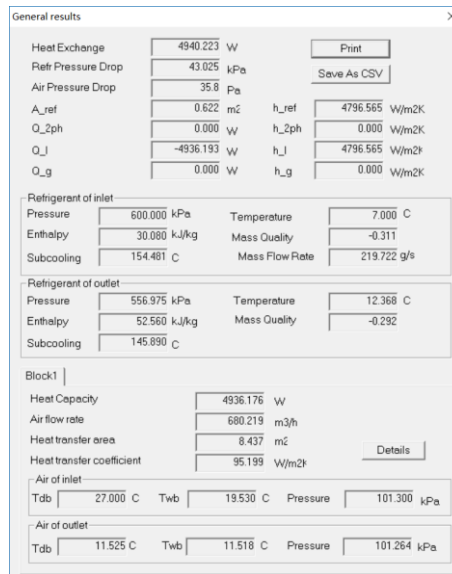


Fig. 9-2 General simulation results

### 9.3 Simulation results of joints

Select menu item **Result | Joints**, a window containing a grid will be shown. In this grid, the simulation results of pressure drop along each joint are shown, just as Fig. 9-3.

Joint	Start tube	End tube	Pressure drop (kPa)
0	Inlet	31	0.012
1	31	21	0.004
2	21	11	0.004
3	11	12	0.004
4	12	1	0.004
5	1	2	0.004
6	2	13	0.004
7	13	3	0.004
8	3	Outlet	0.012
9	Inlet	32	0.012
10	32	33	0.004
11	33	22	0.004

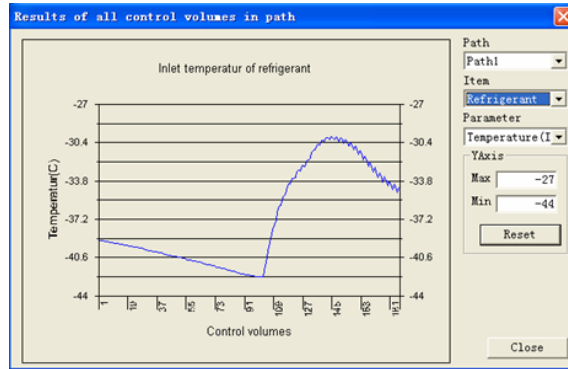
Fig. 9-3 Simulation results of pressure drop along each joint

### 9.4 Simulation results of path

#### 9.4.1 Shown as chart

Select menu item **Result | Result Data in a path | Chart**, a window which contains a chart will show. In this chart, users can see the curve of air and refrigerant parameters of every control volume in every tube in one path. Users can change the display item by selecting the dropdown list of items, and switch path by selecting the dropdown list of paths.

Modifying the maximal value and minimal value can change the range of Y-axis. After users click the button named “Reset”, the new range will impose.



**Fig. 9-4 Show results as charts**

#### 9.4.2 Shown as table

Select menu item **Result | Result Data in a path | Table**, a window which contains a grid will show. In this grid, users can see air and refrigerant parameters of every control volume of every tube in one path. Users can change the display item by selecting the dropdown list of items, and switch path by selecting the dropdown list of paths.

User can save the data by using item “Save as CSV files” in menu “File” of the window of results of all control volumes, just as shown in Fig.9-4. In addition, user can print the result by using item “Print Table” in menu “File” of the window of results of all control volumes.

When the user clicks on this item, a file dialog will be popped out to save the data shown in table as a CSV file.

Column	Control volume	Temperatur (In) (C)	Temperature (Out) (C)
1	1	-39.09	-39.10
1	1	-39.10	-39.10
1	1	-39.10	-39.11
12	1	-39.16	-39.17
12	1	-39.17	-39.18
12	1	-39.18	-39.18
2	1	-39.24	-39.25
2	1	-39.25	-39.25
2	1	-39.25	-39.26
13	1	-39.32	-39.32
13	1	-39.32	-39.33
13	1	-39.33	-39.34
3	1	-39.40	-39.41

**Fig. 9-5 Show results as table**

### 9.5 Show results as colored Graph

When the user selects menu item **Result | Show Results in Graph**, a window will be popped out to show the simulation results of the heat exchanger model. This window is used to show the simulation results in 3-D colored graph, just as Fig. 9-6.

The functions of the menu items in the Results Window have been explained in preamble. Here we will explain the view setup of the Results Window.

If users select the menu item **View | View Setup** in the menu of the Results Window, a dialog widow will show in which users can change some characters of the view of the Results Window,

just as shown in Fig. 9-7.

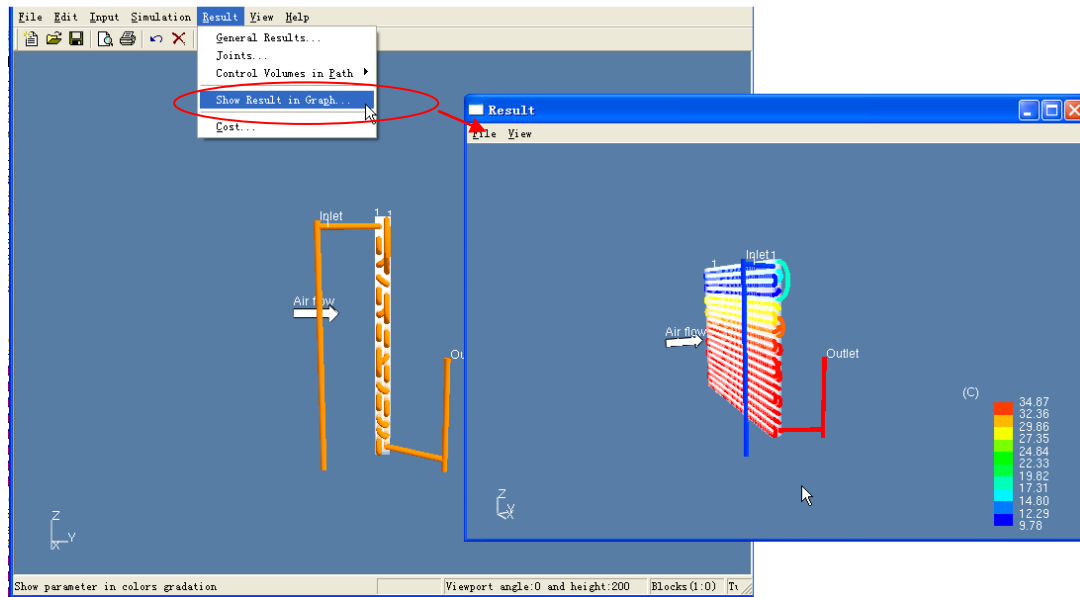


Fig. 9-6 Simulation results shown as 3-D colored graph

#### 9.4.1 View of setup

At the top of this page, there are a check box listing some parameters such as refrigerant temperature, refrigerant pressure, just as Fig. 9-7.

User can choose one of these parameters by checking corresponding check box. The parameter selected will be shown in color gradation to represent the change of this parameter of refrigerant along flow path in 3-D view, just as shown in Fig. 9-8.

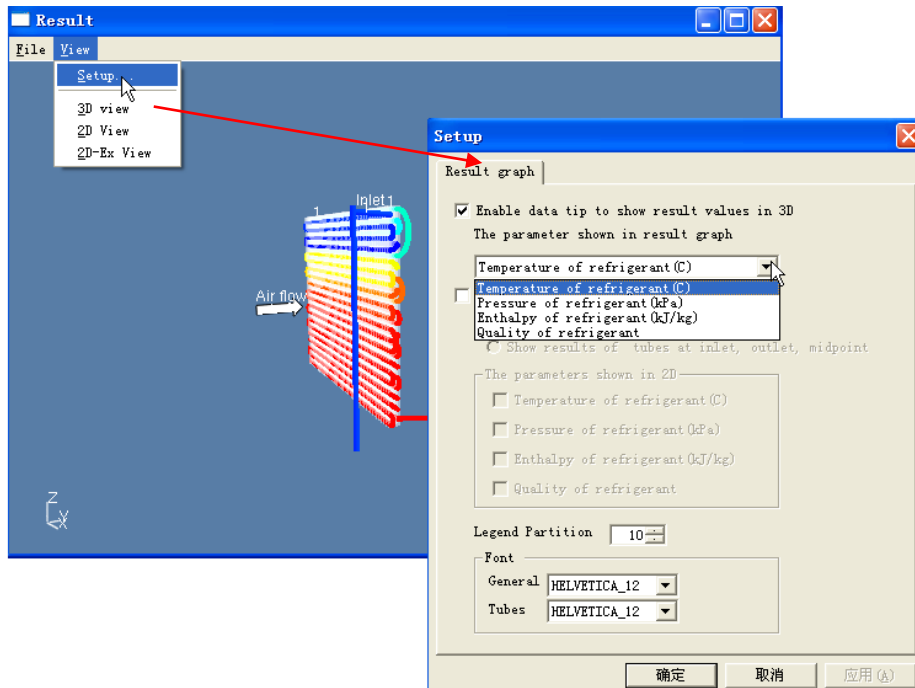


Fig. 9-7 View of setup window

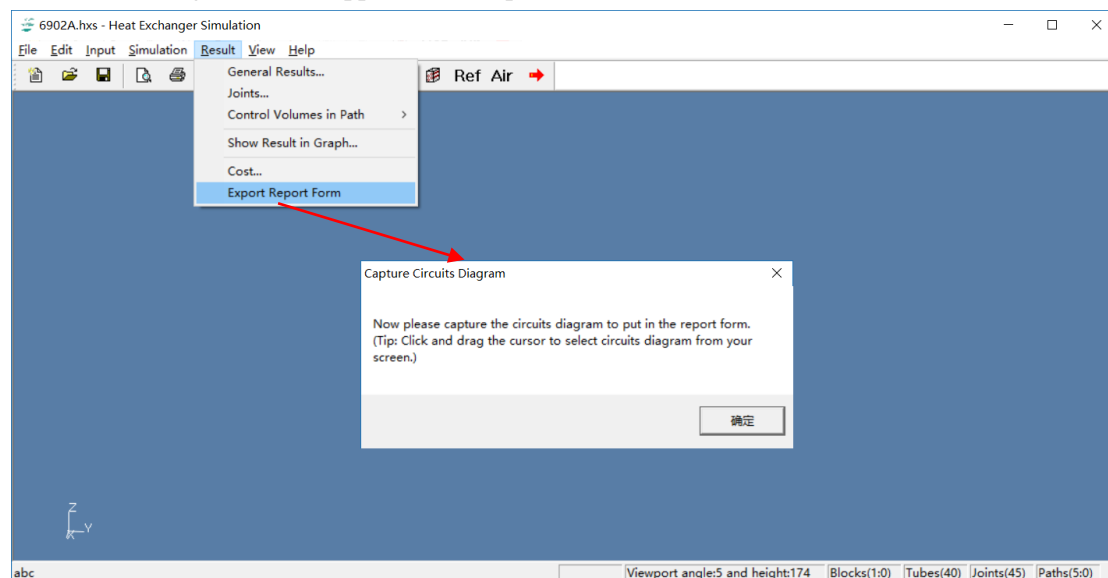


**Fig. 9-8 Enthalpy gradation**

## 9.5 Export Report Form

This function provides an access to export the report form with printer. After the simulation has finished, users can conveniently export report form with most details (structure, circuits, air side and refrigerant side properties) of the design.

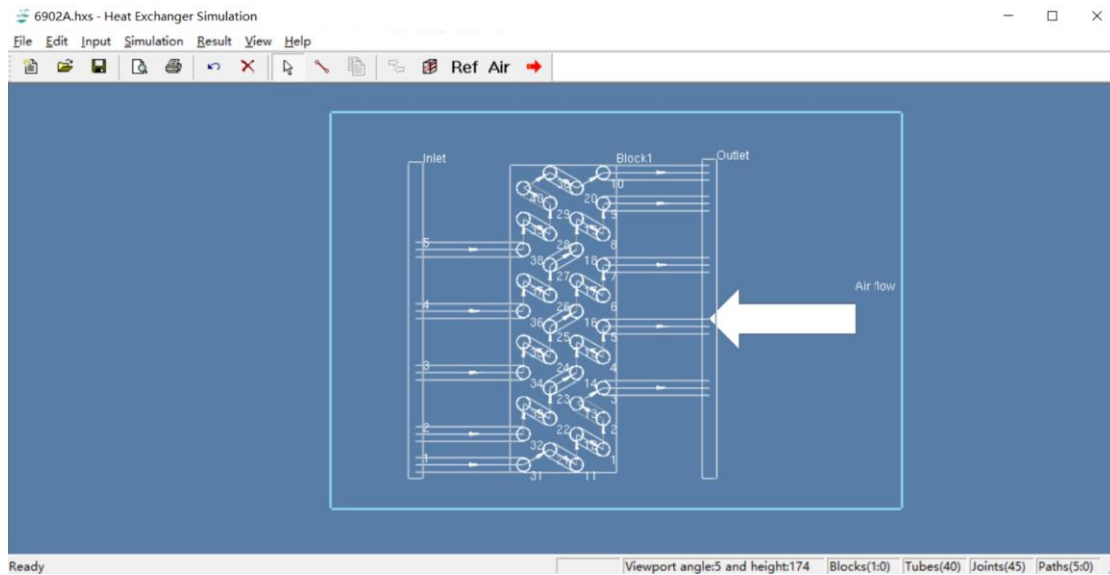
First, click “Export Report Form” and a message would appear to prompt user to capture circuit diagram. It is highly recommended to switch to 2D view beforehand to make the diagram clearer. This diagram would appear in the report form.



**Fig. 9-9 Calling Export Report Form Function**

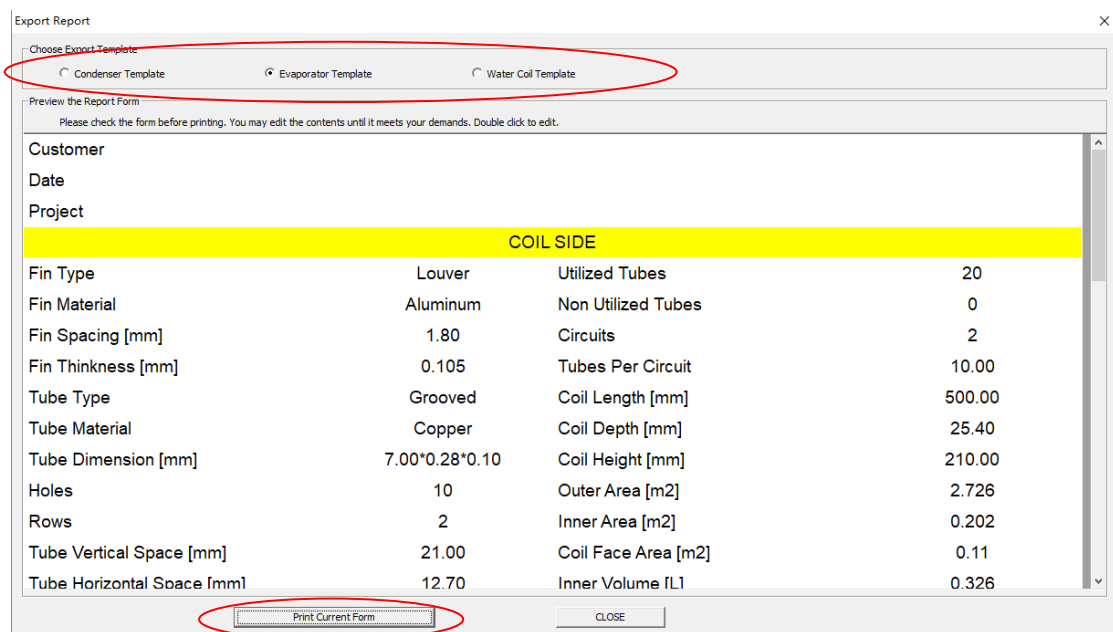
Drag the cursor to select circuits diagram.





**Fig. 9-10 Capture circuits diagram**

Then the report form preview appears. Users may select from 3 given templates, check the data and edit the form to make sure it meets the demands.



**Fig. 9-11 Select template and print form**

At last, click “Print Current Form” and users may choose to export .pdf files or to print it with a printer.

## 10 Operation steps and examples

### 10.1 Operation steps

When building a new fin-and-tube heat exchanger and use the simulator to calculate it, the detailed operation steps are follows:

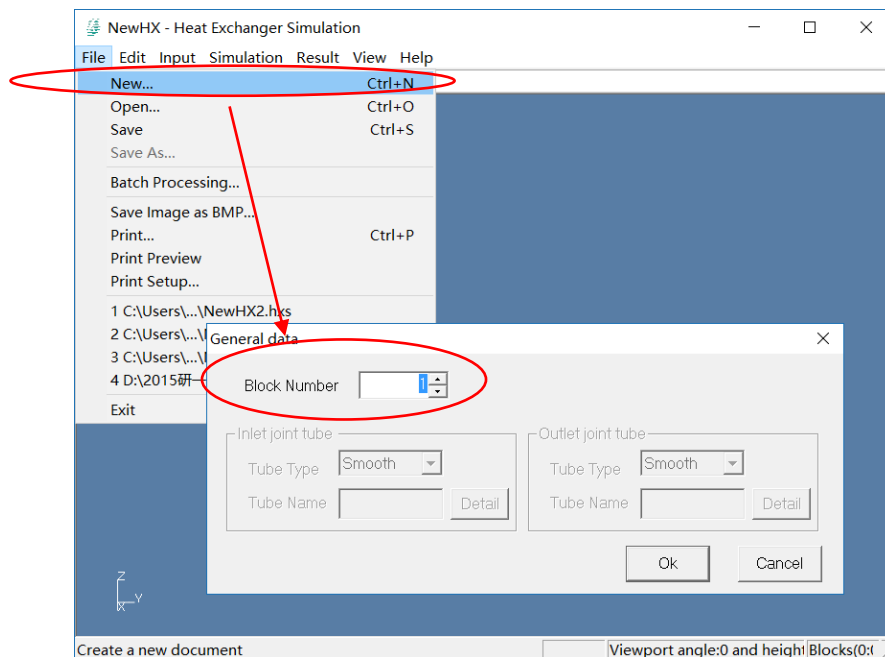
- (1) Click on the menu item **File| New**, and define block number in the general data dialog.
- (2) (Optional) Click on the menu item **Input| General Data** to add blocks.
- (3) Click on the menu item **Input| Block**, select fin and tube from database and set the structure parameters of blocks.
  - (a) Click on the button “Fins” to specify the parameters of fins from database.
  - (b) Click on the button “Rows” to set the column number of rows.
  - (c) Click on the button “Tubes” to specify the parameters of tubes from database.
- (4) Click on the menu item **Input| Refrigerant**, and set the input parameters of refrigerant.
- (5) Click on the menu item **Input| Air**, and set the input parameters of air.
- (6) Connect the tubes according to the tubes connection example that is introduced in Chapter 10.2.
- (7) Click on the menu item **Simulation| Run** to run the simulation.
- (8) When the simulation finished, click on the menu item **Result| General Results** to see the simulation results.
- (9) Click “Export Report Form” to export a report.

## 10.2 Example of operation steps for I typed heat exchanger

The following example will show how to build a fin-and-tube heat exchanger and use simulator to calculate it.

### 10.2.1 Step 1: Create an I typed fin-and-tube heat exchanger

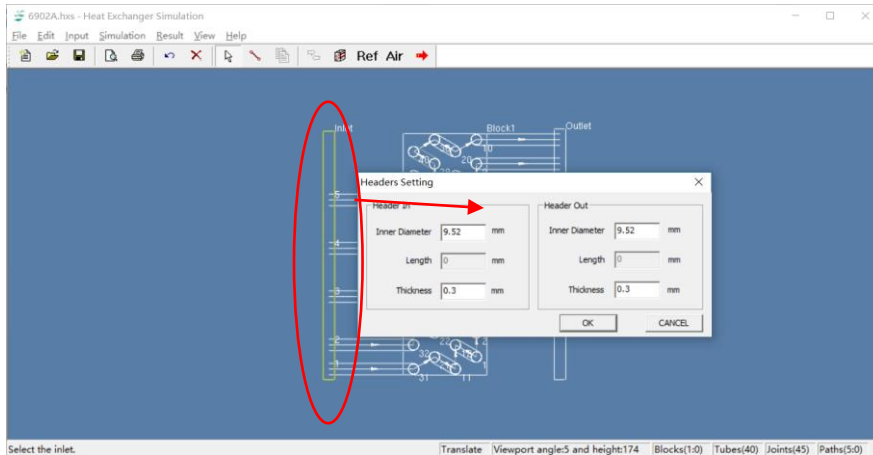
Click on the menu item **File| New**, and define block number in the general data dialog, just as the Fig. 10-1.



**Fig. 10-1 Create a new heat exchanger and define block number**

## 10. 2.2 Step 2: Define inlet and outlet tube types

Double-click on the inlet tube or outlet tube on the screen to set its parameters.



**Fig. 10-2 Define inlet and outlet tube types**

## 10. 2.3 Step 3: Set Structure of I typed heat exchanger

**Step 5.1:** Click “Fins” to select fin structure from database.

**Step 5.2:** Input row number, then click “Rows” to Input Column number and row space.

**Step 5.3:** Click “Tubes” to set tubes.

(1) Click on button “Tubes” on dialog “Input” to open dialog “Tubes”.

(2) Set each tube type:

Press button “Specify tube type” to open tube type dialog.

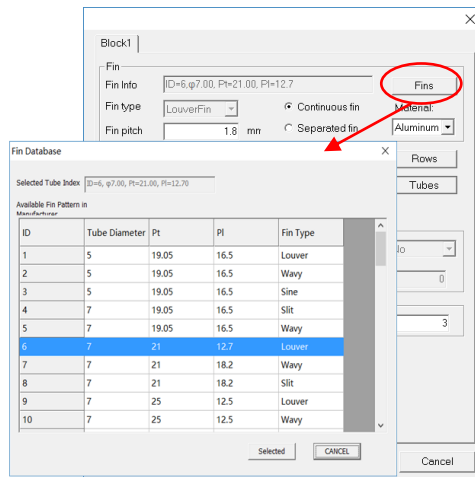
Select tube structure from database.

(3) Set Column space

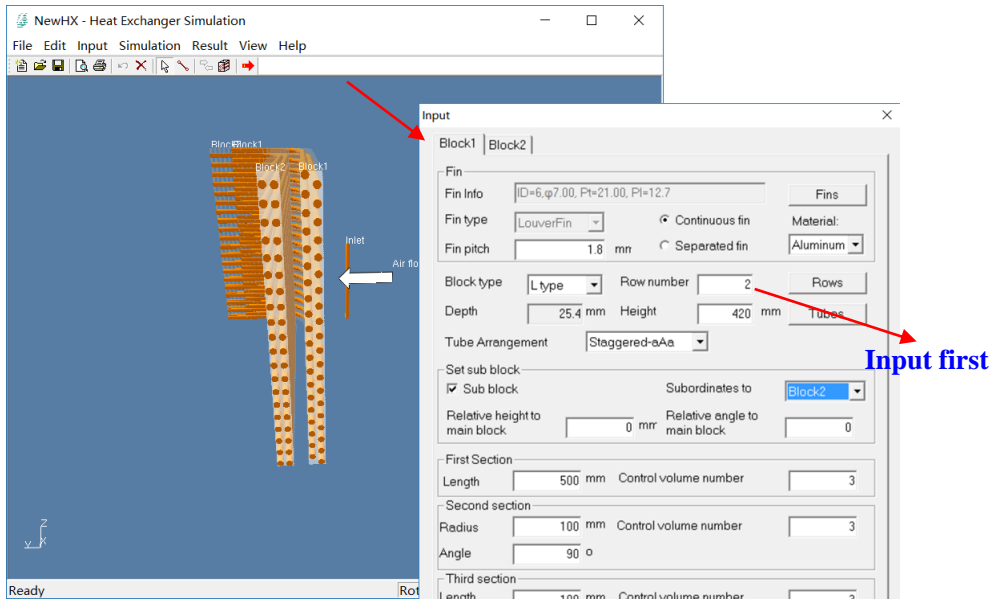
At most times, simply select “staggered” or “inline” tube arrangement (*Block-> Tube Arrangement*) can quickly set all column spaces. If necessary, select “Custom” tube arrangement and then manually specify every column space here.

**Step 5.5:** Input fin pitches, tube arrangement, fin material, (if necessary) sub-block

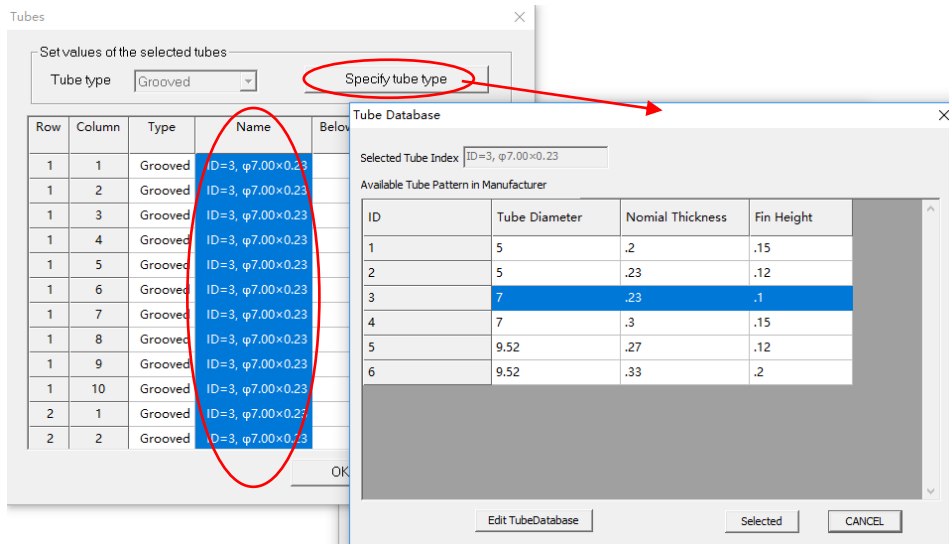
Input constant fin pitch in Block dialog; select tube arrangement and fin material.



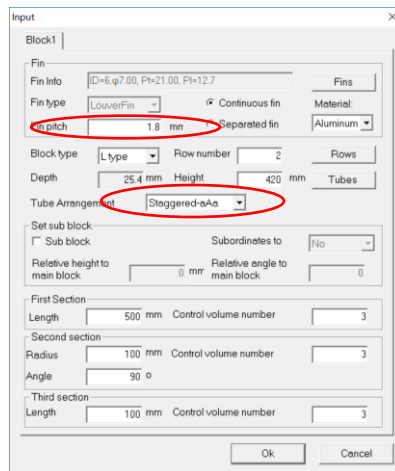
**Fig. 10-3 Set Fins parameters**



**Fig. 10-4 Input dimensions of fin-and-tube heat exchanger**



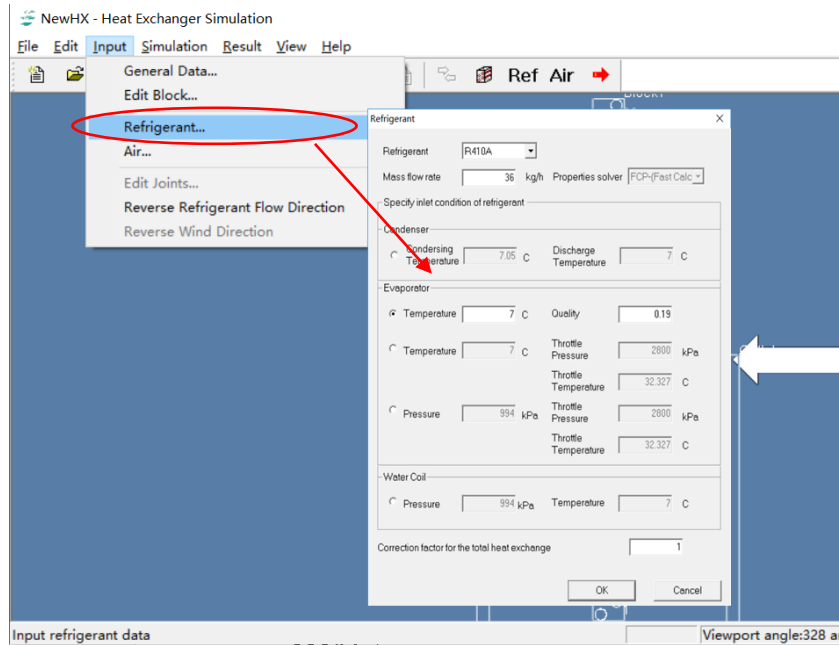
**Fig. 10-6 Input tube types**



**Fig. 10-7 Set Fin pitch and Tube Arrangement**

**10. 2.4 Step 4: Input refrigerant parameters**

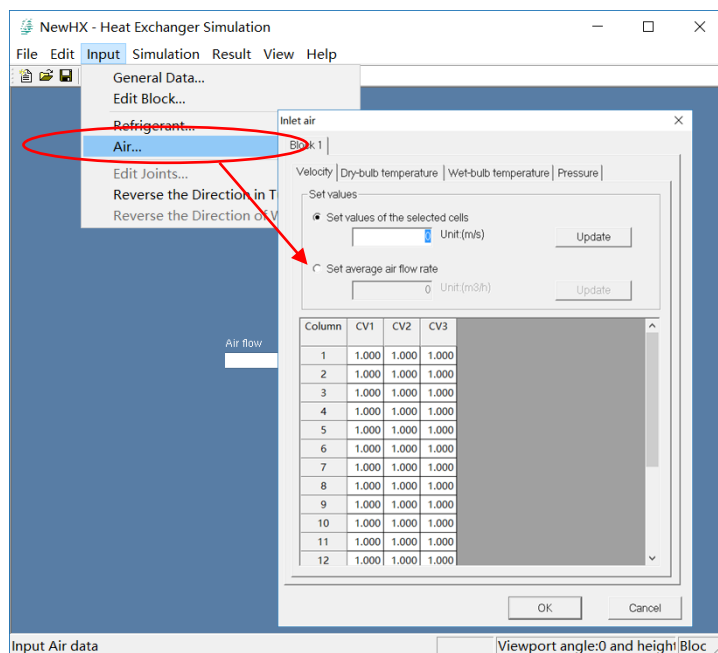
(1) Click on the menu item **Input| Refrigerant**, and set the input parameters of refrigerant.



**Fig. 10-8 Input refrigerant parameters**

**10. 2.5 Step 5: Input air status**

(1) Click on the menu item **Input| air**, and set the input parameters of air.



**Fig. 10-9 Input air status**

### 10. 2.6 Step 6: Connect Tubes

#### Step 6.1: Connect tubes

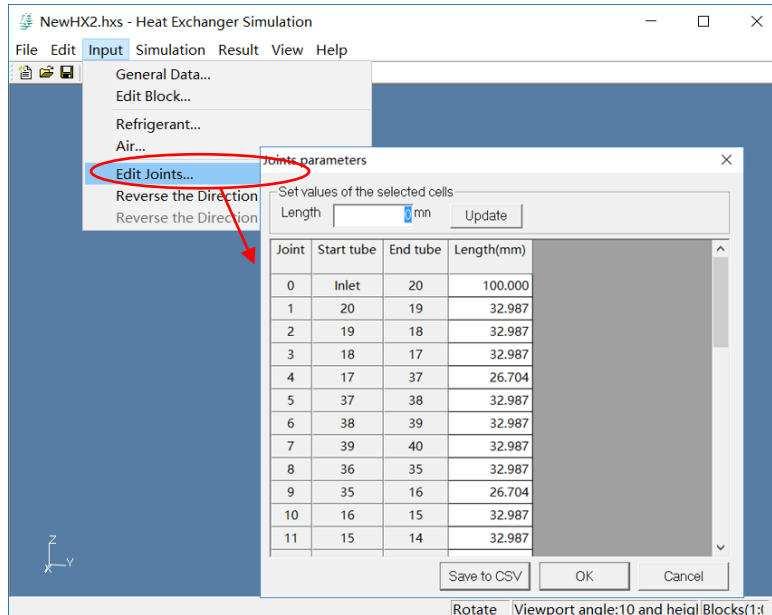
Connect tubes as Fig 10-10 and the method of tubes connection is shown in chapter 6.



**Fig. 10-10 Tubes circuitry**

#### Step 6.2: Set joint length

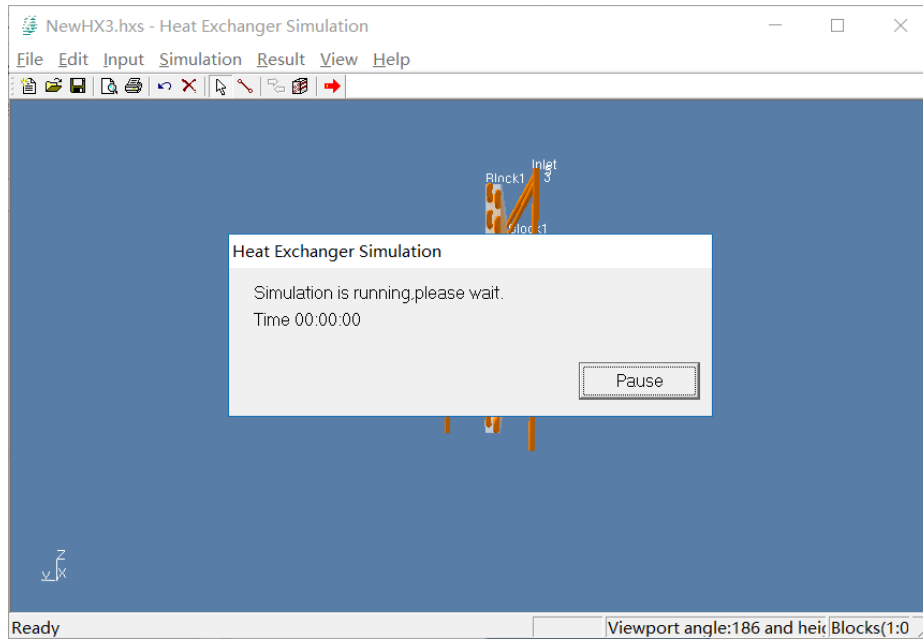
Click on menu **Input | Edit Joint** to set joint length, just as Fig. 10-11.



**Fig. 10-11 Set joint length**

## 10. 2.7 Step 7: Run Simulation

Click the menu **Simulate | Run** to Run simulation, just as Fig. 10-12.



**Fig. 10-12 Run Simulation**

## 10. 2.8 Step 8: See results

### *Step 8.1 General results*

Press menu "**Result | General results**" to see general results, just as Fig. 10-13.

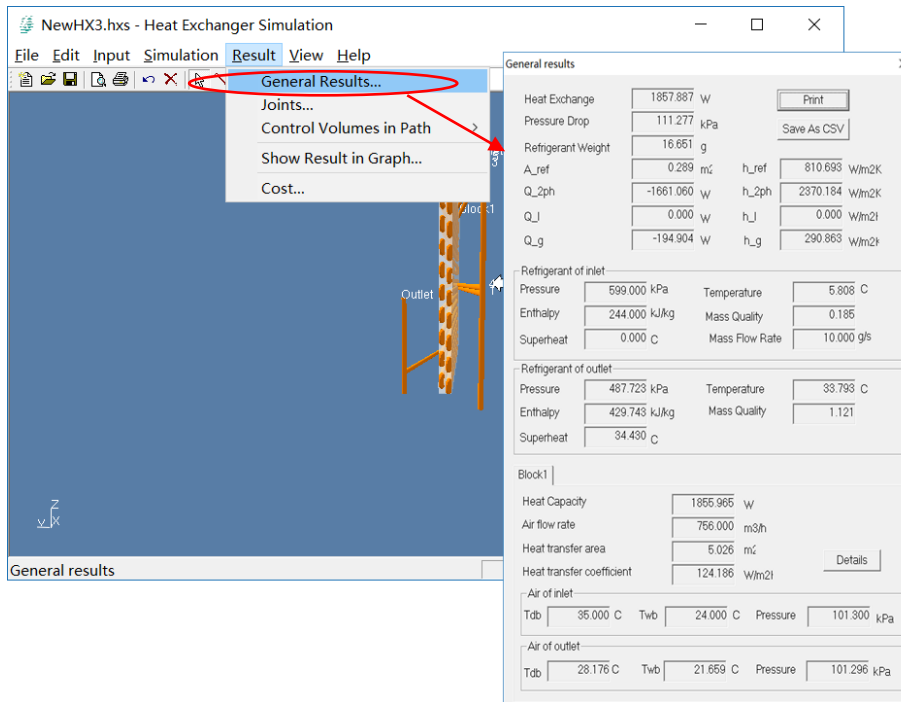


Fig. 10-13 General results

**Step 8.2 Pressure drop of Joints**

Press menu “**Result | Joints**” to see pressure drop of joints, just as Fig. 10-14.

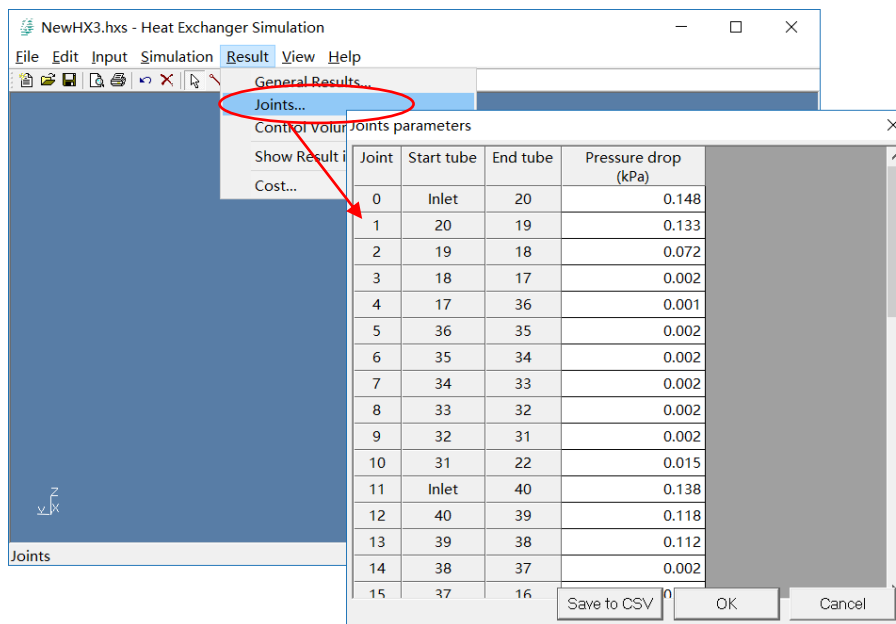


Fig. 10-14 Pressure drop of Joints

**Step 8.3 Simulation results of control volume in path**

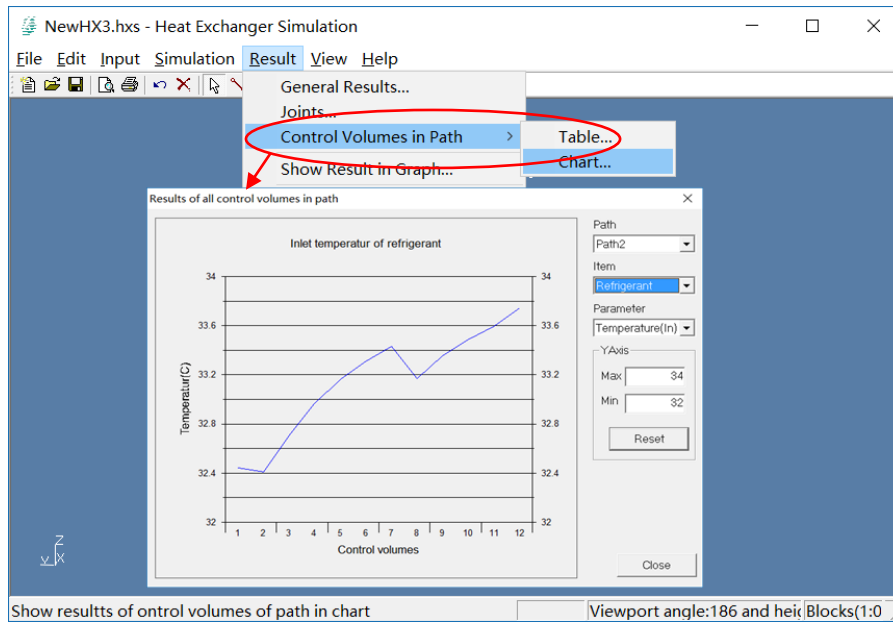
**Option 1: Simulation results shown as chart**

Press menu “**Result | Control volume in path | Chart**” to see simulation results of control volumes in chart, just as Fig. 10-15.

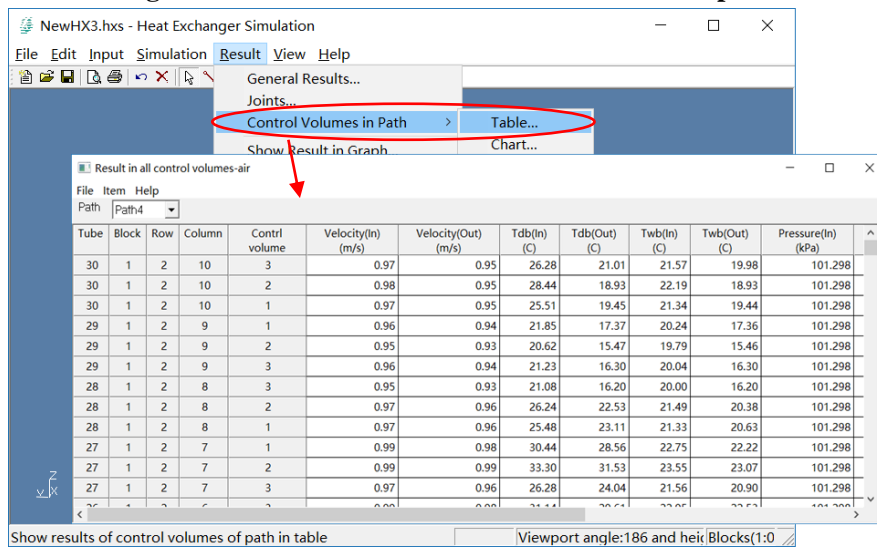
**Option 2: Simulation results shown as table**



Press menu “**Result | Control volume in path | Table**” to see simulation results of control volumes in table, just as Fig. 10-16.



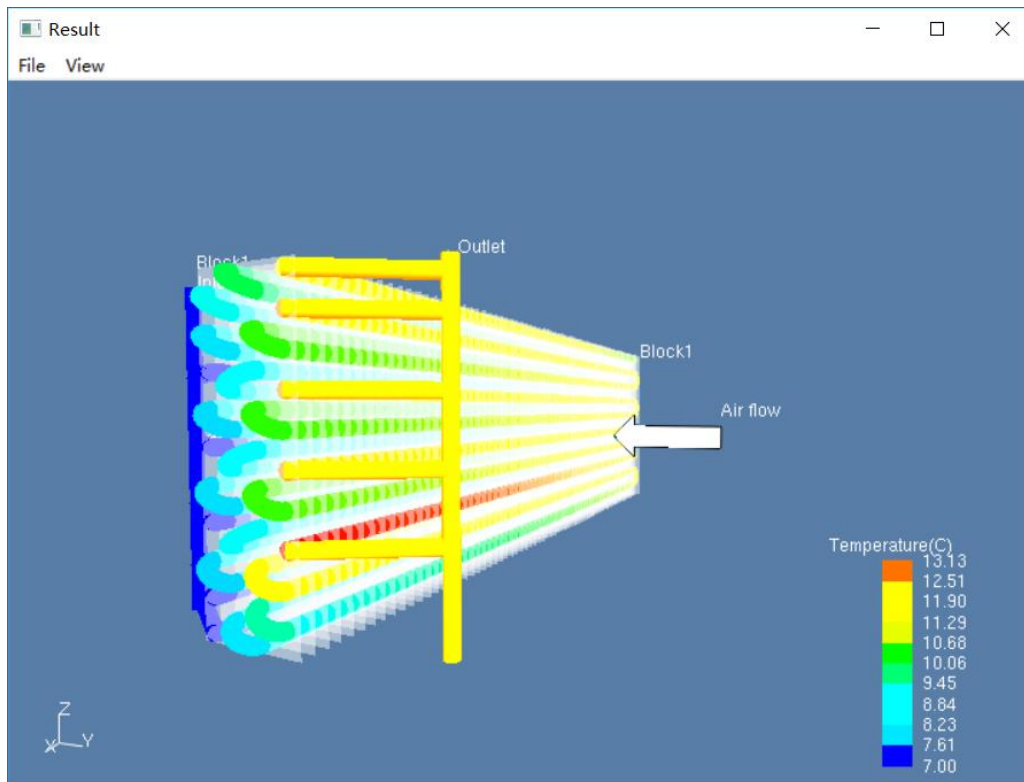
**Fig. 10-15 Simulation results of control volume in path shown as chart**



**Fig. 10-16 Simulation results of control volume in path in table**

**Step 8.4 Simulation results in color gradation**

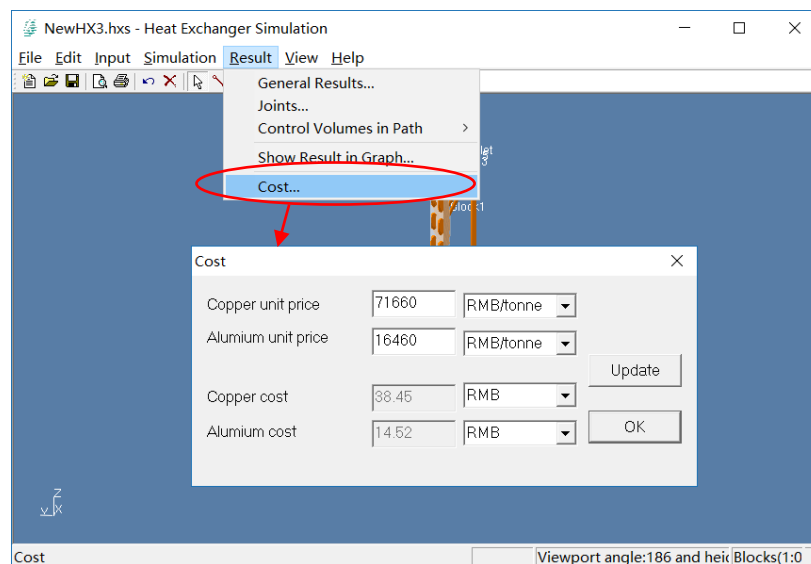
Press menu “**Result | Show results in graph**” to see simulation results of control volumes in chart, just as Fig. 10-17.



**Fig. 10-17 Simulation results in color gradation**

**Step 8.5 Cost**

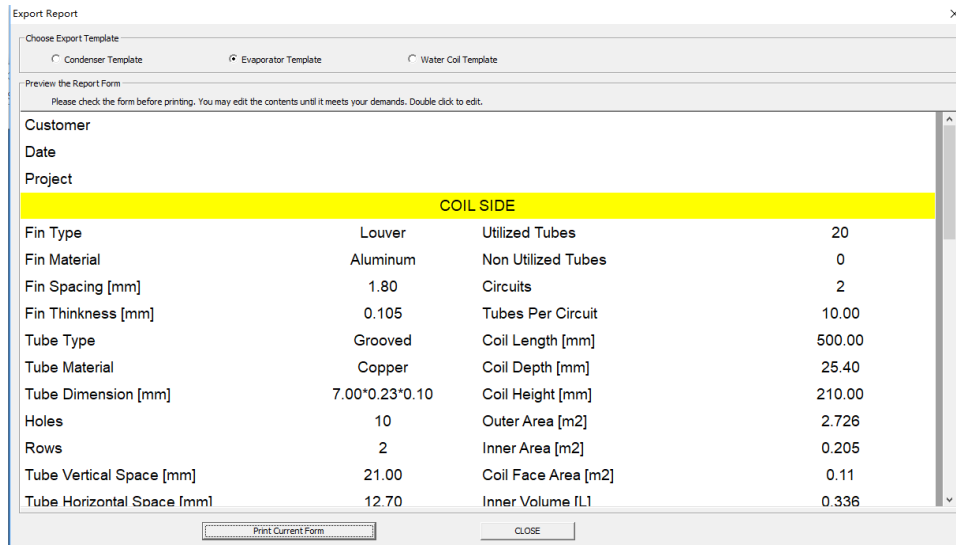
Press menu “**Result | Cost**” to see copper cost and aluminum cost, just as Fig. 10-18.



**Fig. 10-18 Cost**

**10. 2.9 Step 9: Export Report Form**

Click “Export Report Form” to export a report. Capture circuits diagram, preview and edit, then click “print” to export Report form.



**Fig. 10-19 Select template and print form**

### 10.3 Example of operation steps for L typed heat exchanger

The following example will show how to build an L typed fin-and-tube heat exchanger and use simulator to calculate it.

#### 10. 3.1 Step 1: Create an L typed fin-and-tube heat exchanger

Click on the menu item **File| New**, and define block number in the general data dialog, just as shown in Chapter 10.2.1.

#### 10. 3.2 Step 2: Define inlet and outlet tube types

(1) Click on menu item **Input| General Data**, and set the tube type for the inlet tube and outlet tube.

(2) Click on button “Detail” to open tube type dialog and select existed tube type, just as shown in Chapter 10.2.2.

#### 10. 3.3 Step 3: Input refrigerant parameters

Click on the menu item **Input| Refrigerant**, and set the input parameters of refrigerant, just as shown in Chapter 10.2.3.

#### 10. 3.4 Step 4: Input air status

Click on the menu item **Input| air**, and set the input parameters of air, just as shown in

### 10. 3.5 Step 5: Set Structure of L typed heat exchanger

#### Step 5.1: Input dimensions of L typed fin-and-tube heat exchanger, just as Fig. 10-21.

In this dialog, users need to input the dimension parameters of L typed heat exchanger, including the length of the first section, radius and angle (90° ) of the second section and the length of the third section, as shown in Fig.10-20.

The following steps are as same as shown in Chapter 10.3.5.

#### Step 5.2: Select fins structure

#### Step 5.3: Input Column number and row space.

#### Step 5.4: Input tubes structure

#### Step 5.5: Input fin pitches and tube arrangement

Input constant fin pitch and select tube arrangement in Block dialog.

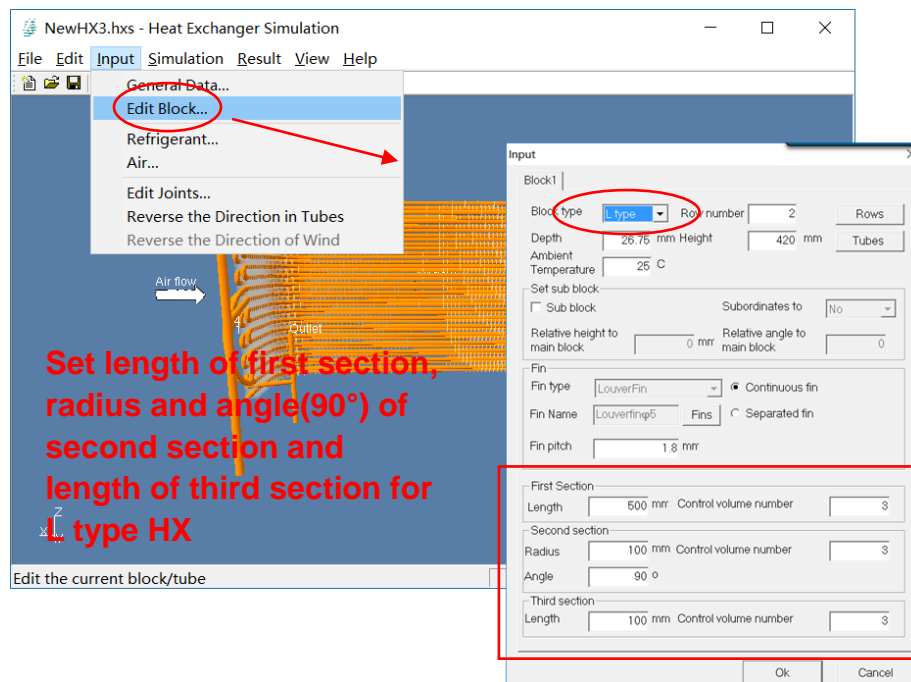
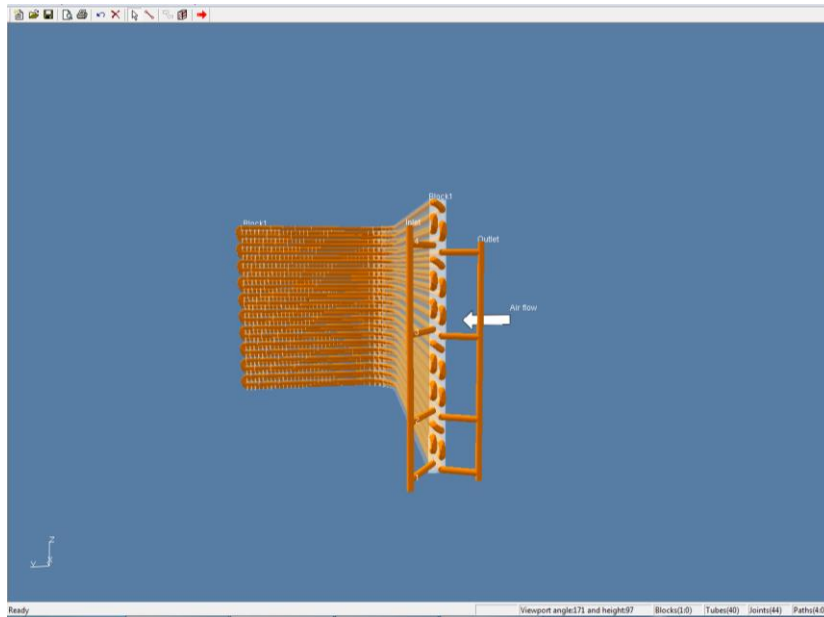


Fig. 10-20 Input dimensions of L typed fin-and-tube heat exchanger

### 10. 3.6 Step 6: Connect Tubes

#### Step 6.1: Connect tubes

Connect tubes as Fig 10-21 and the method of tubes connection is shown in chapter 6.



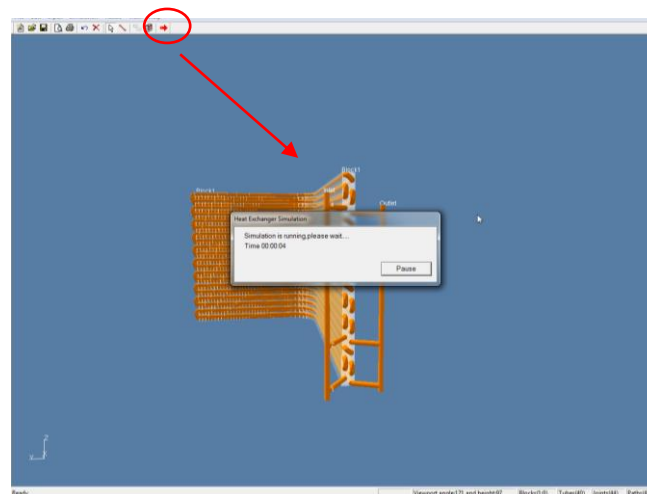
**Fig. 10-21 Tubes circuitry**

**Step 6.2: Set joint length**

Click on menu **Input | Edit Joint** to set joint length, just as shown in Chapter 10.3.6.

**10. 3.7 Step 7: Run Simulation**

Click the menu **Simulate | Run** to Run simulation, just as Fig. 10-22.

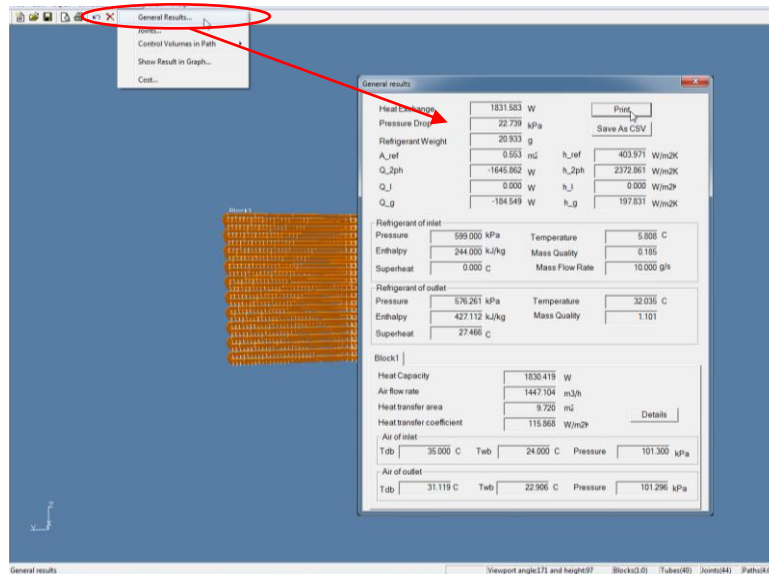


**Fig. 10-22 Run Simulation**

**10. 3.8 Step 8: See results**

**Step 8.1 General results**

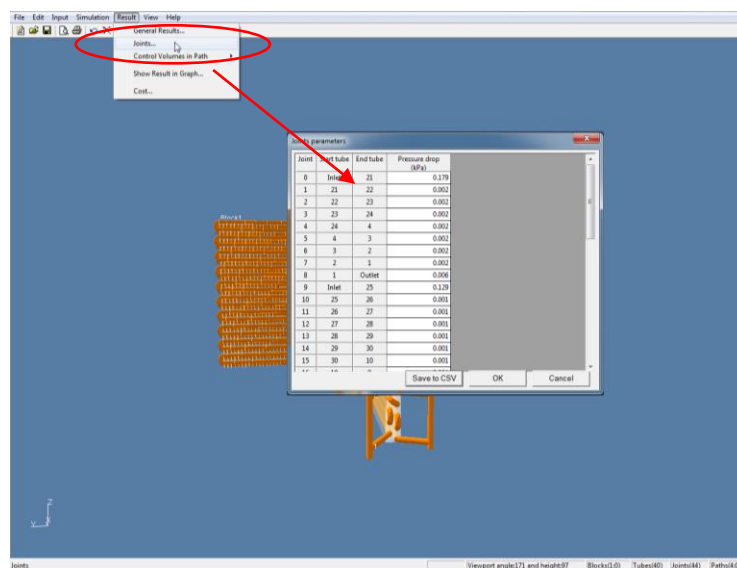
Press menu “**Result | General results**” to see general results, just as Fig. 10-23.



**Fig. 10-23 General results**

**Step 8.2 Pressure drop of Joints**

Press menu “**Result | Joints**” to see pressure drop of joints, just as Fig. 10-24.



**Fig. 10-24 Pressure drop of Joints**

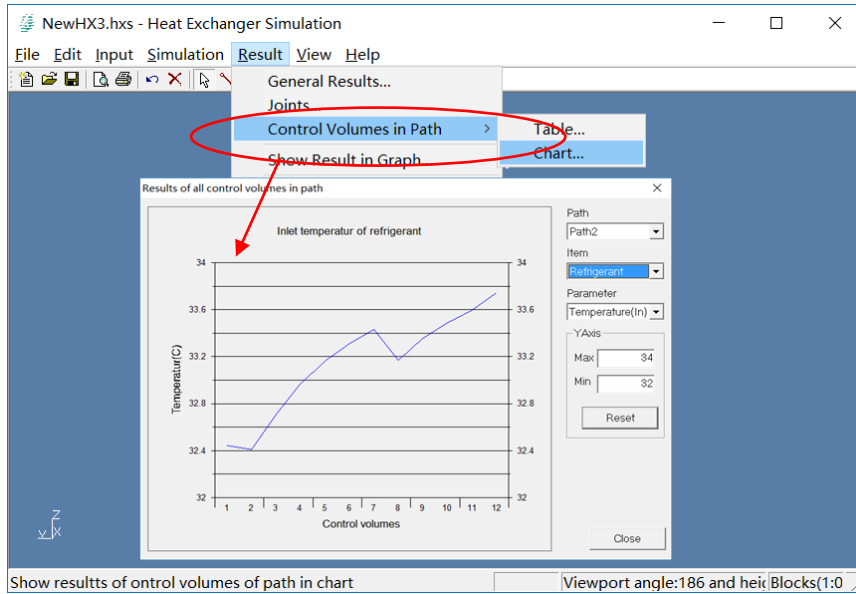
**Step 8.3 Simulation results of control volume in path**

**Option 1: Simulation results shown as chart**

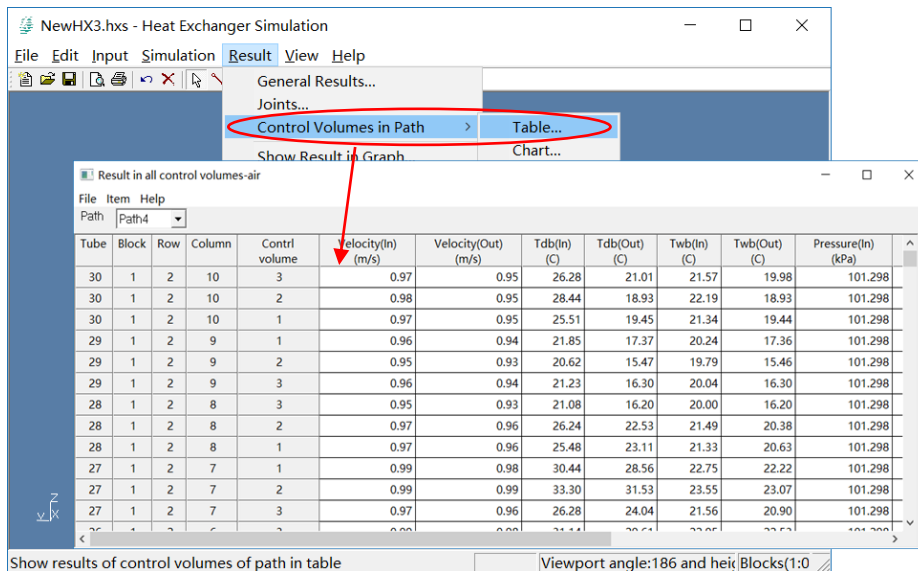
Press menu “**Result | Control volume in path | Chart**” to see simulation results of control volumes in chart, just as Fig. 10-25.

**Option 2: Simulation results shown as table**

Press menu “**Result | Control volume in path | Table**” to see simulation results of control volumes in table, just as Fig. 10-26.



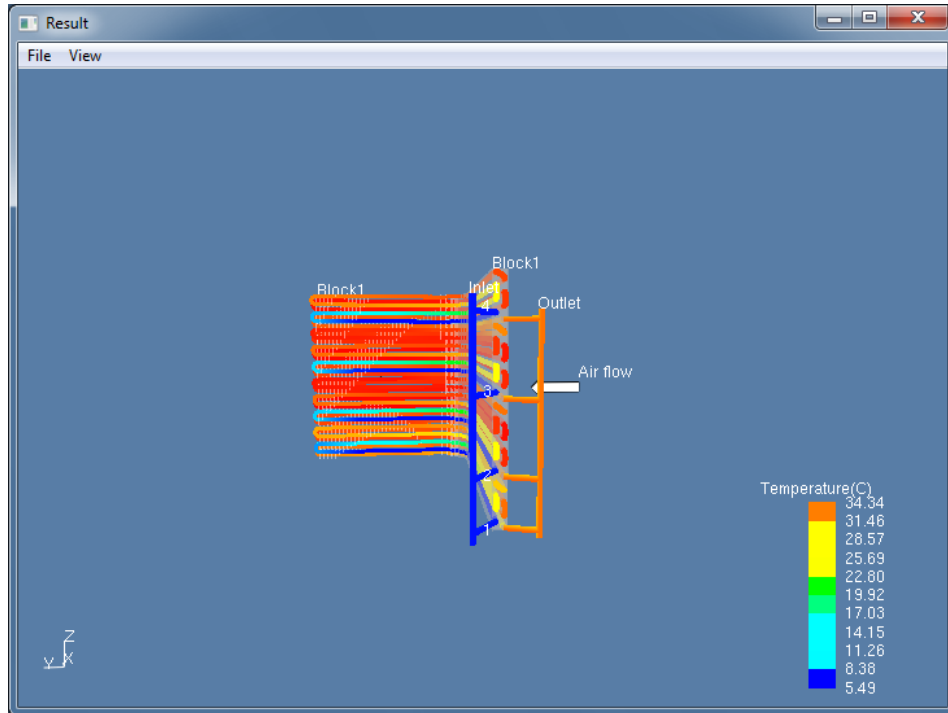
**Fig. 10-25 Simulation results of control volume in path shown as chart**



**Fig. 10-26 Simulation results of control volume in path in table**

**Step 8.4 Simulation results in color gradation**

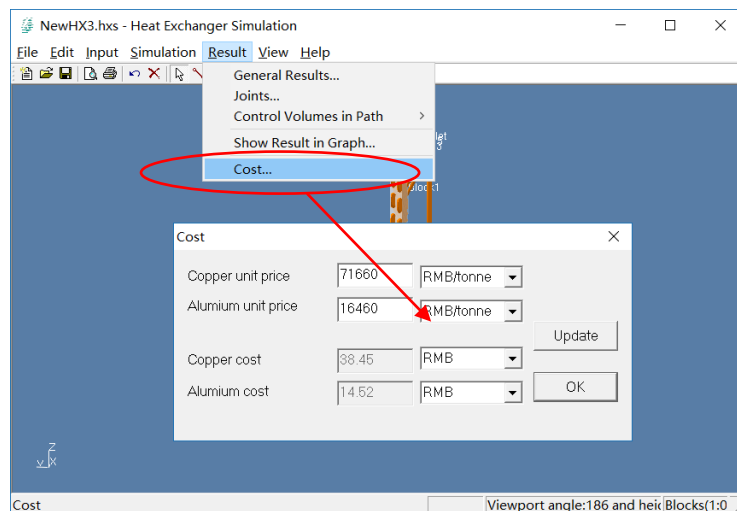
Press menu “**Result | Show results in graph**” to see simulation results of control volumes in chart, just as Fig. 10-27.



**Fig. 10-27 Simulation results in color gradation**

**Step 8.5 Cost**

Press menu “**Result | Cost**” to see copper cost and aluminum cost, just as Fig. 10-28.

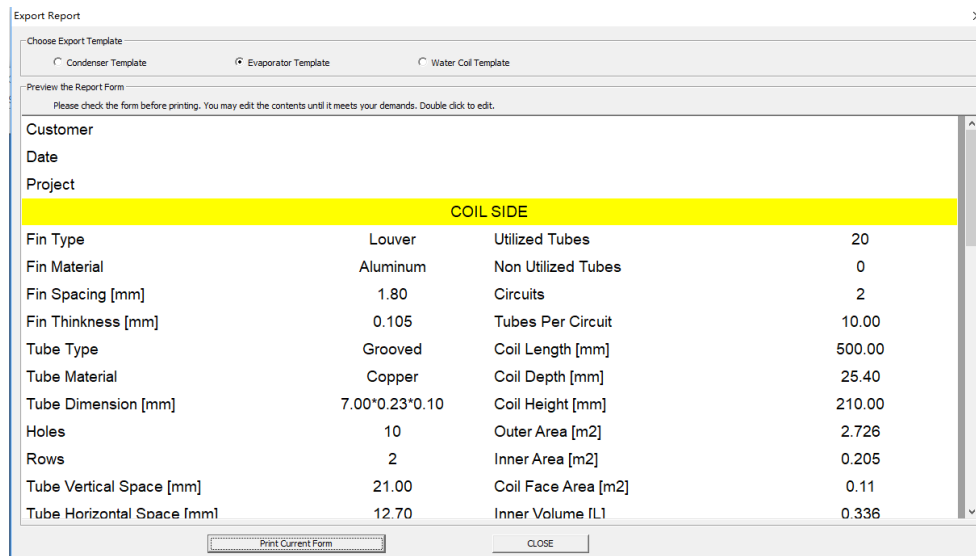


**Fig. 10-28 Cost**

**10. 2.9 Step 9: Export Report Form**

Click “Export Report Form” to export a report. Capture circuits diagram, preview and edit, then click “print” to export Report form.





**Fig. 10-29 Select template and print form**

## 10.4 Example of operation steps for C typed heat exchanger

The following example will show how to build a C typed fin-and-tube heat exchanger and use simulator to calculate it.

### 10.4.1 Step 1: Create a C typed fin-and-tube heat exchanger

Click on the menu item **File| New**, and define block number in the general data dialog, just as shown in Chapter 10.2.1.

### 10.4.2 Step 2: Define inlet and outlet tube types

(1) Click on menu item **Input| General Data**, and set the tube type for the inlet tube and outlet tube.

(2) Click on button "Detail" to open tube type dialog and select existed tube type, just as shown in Chapter 10.2.2.

### 10.4.3 Step 3: Input refrigerant parameters

Click on the menu item **Input| Refrigerant**, and set the input parameters of refrigerant.

### 10.4.4 Step 4: Input air status

Click on the menu item **Input| air**, and set the input parameters of air.

### 10.4.5 Step 5: Set Structure of C typed heat exchanger

*Step 5.1: Input dimensions of fin-and-tube heat exchanger, just as Fig. 10-30.*

In this dialog, users need to input the dimension parameters of L typed heat exchanger, including the length of the first section, radius and angle (180° )of second section and the length of the third section, as shown in Fig. 10-30.

*The following steps are as same as shown in Chapter 10.3.5.*

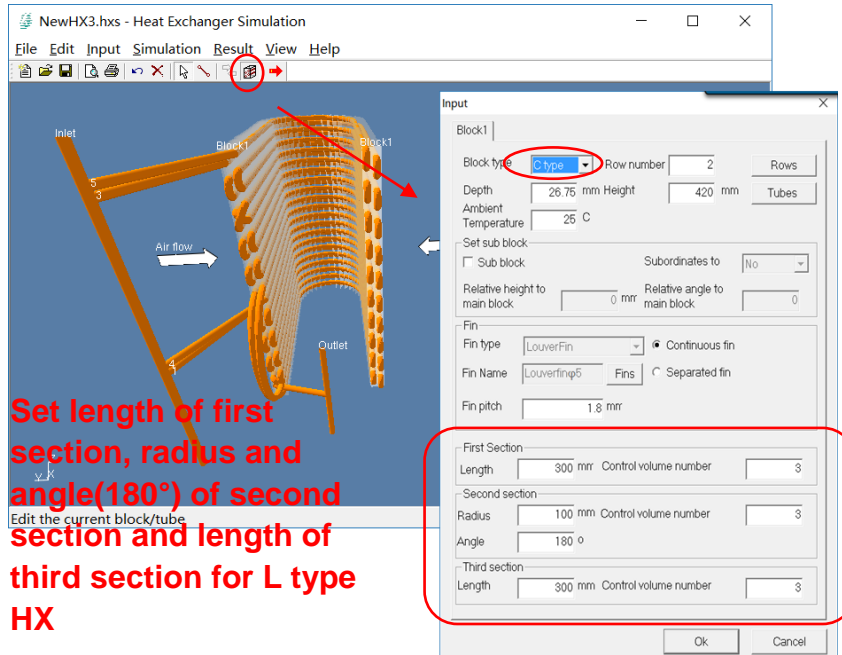
**Step 5.2: Select fins structure**

**Step 5.3: Input Column number and row space.**

**Step 5.4: Input tubes structure**

**Step 5.5: Input fin pitches and tube arrangement**

Input constant fin pitch and select tube arrangement in Block dialog.

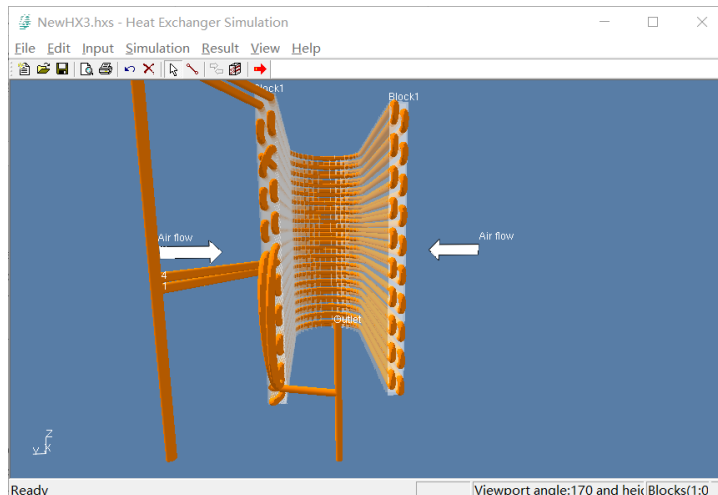


**Fig. 10-30 Input dimensions of C typed fin-and-tube heat exchanger**

## 10.4.6 Step 6: Connect Tubes

### Step 6.1: Connect tubes

Connect tubes as Fig 10-31 and the method of tubes connection is shown in chapter 6.



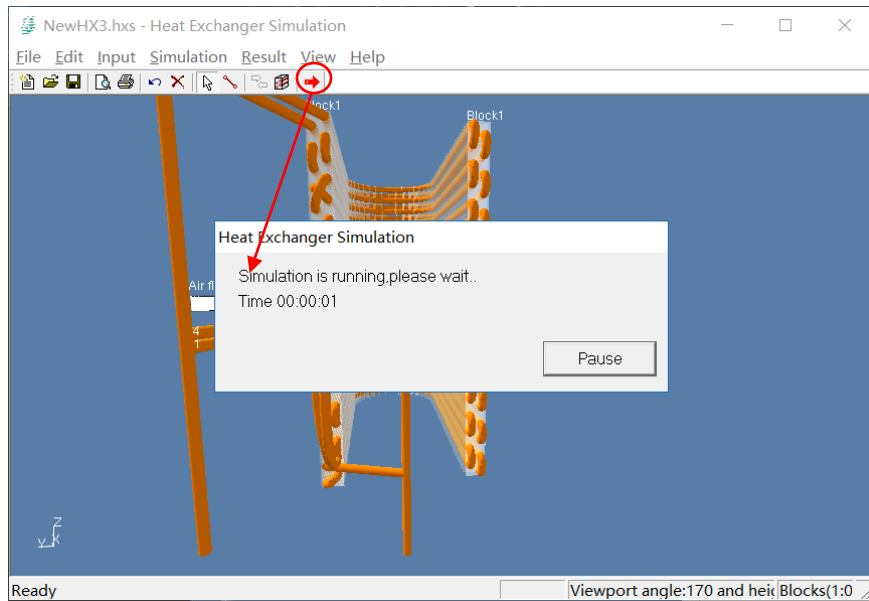
**Fig. 10-31 Tubes circuitry**

**Step 6.2: Set joint length**

Click on menu **Input | Edit Joint** to set joint length, just as shown in Chapter 10.2.6.

**10. 4.7 Step 7: Run Simulation**

Click the menu **Simulate | Run** to Run simulation, just as Fig. 10-32.



**Fig. 10-32 Run Simulation**

**10. 4.8 Step 8: See results**

**Step 8.1 General results**

Press menu “**Result | General results**” to see general results, just as Fig. 10-33.

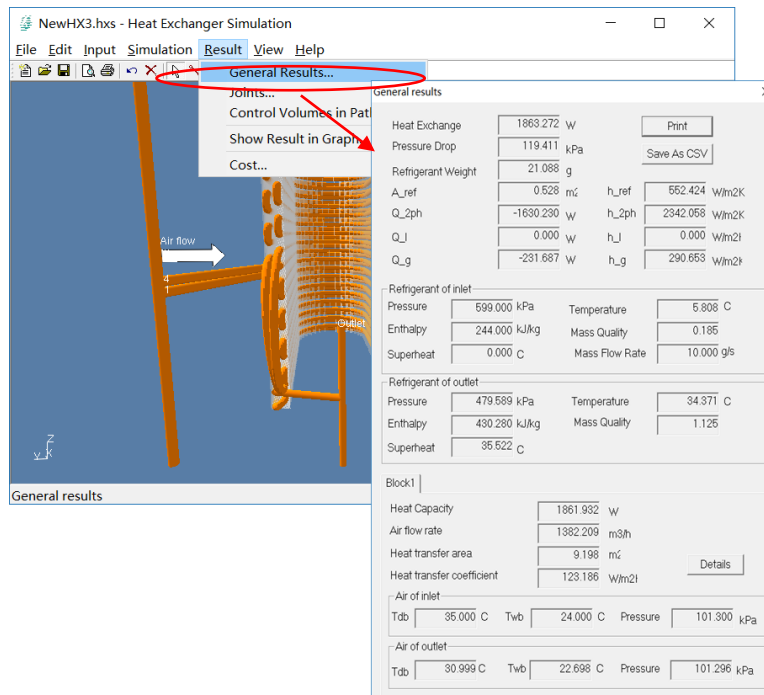


Fig. 10-33 General results

### Step 8.2 Pressure drop of Joints

Press menu “**Result | Joints**” to see pressure drop of joints, just as Fig. 10-34.

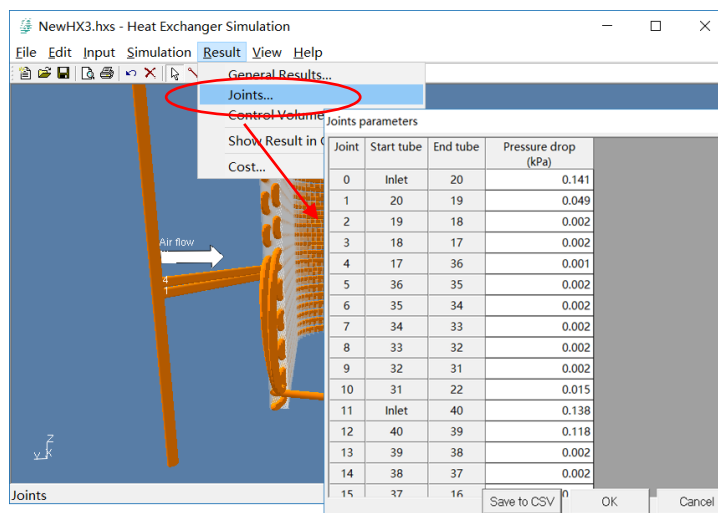


Fig. 10-34 Pressure drop of Joints

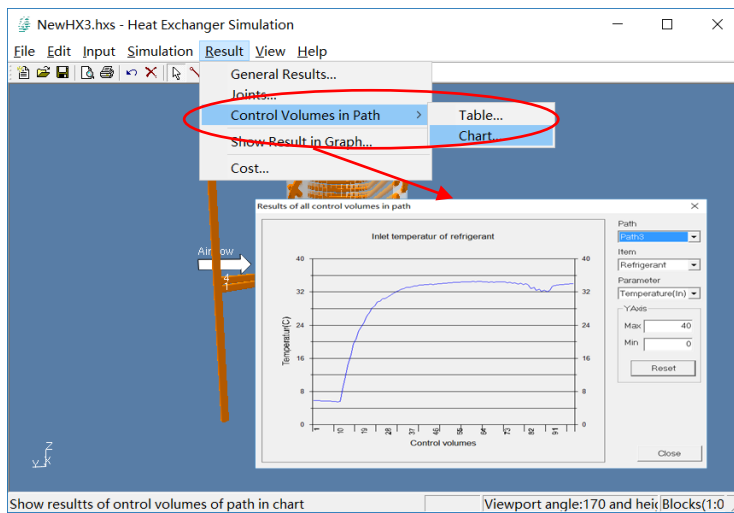
### Step 8.3 Simulation results of control volume in path

#### Option 1: Simulation results shown as chart

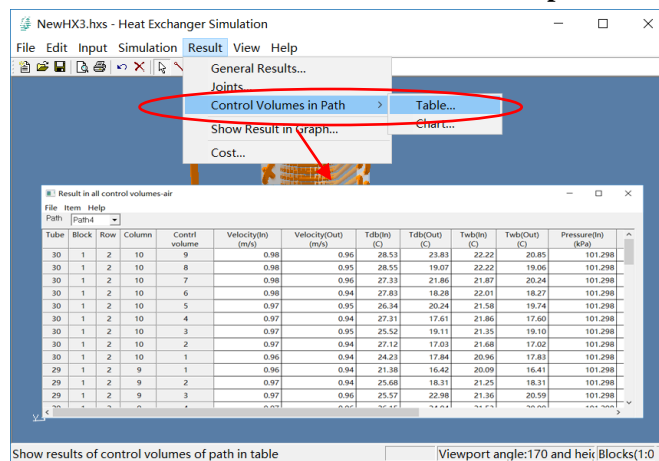
Press menu “**Result | Control volume in path | Chart**” to see simulation results of control volumes in chart, just as Fig. 10-35.

#### Option 2: Simulation results shown as table

Press menu “**Result | Control volume in path | Table**” to see simulation results of control volumes in table, just as Fig. 10-36.



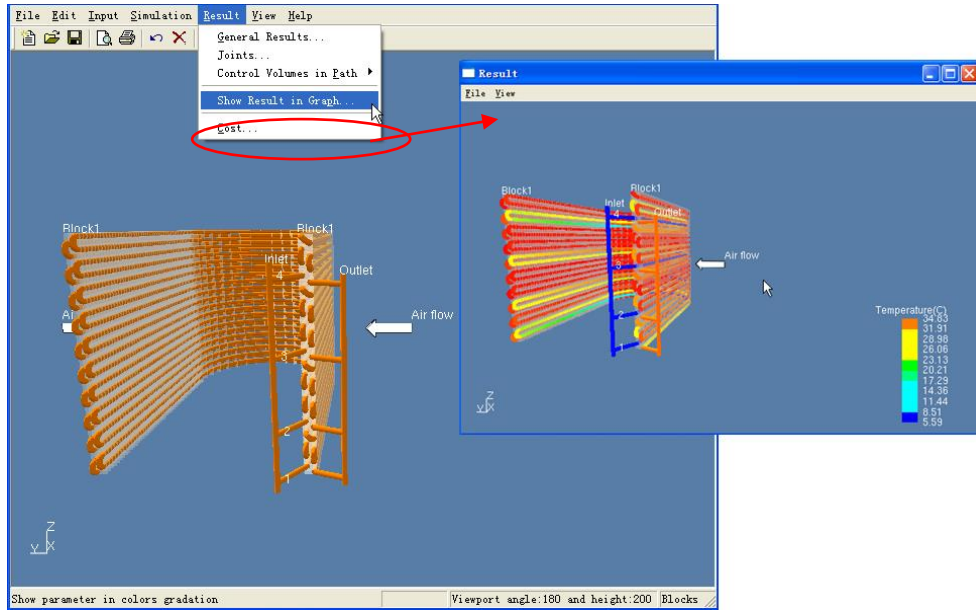
**Fig. 10-35 Simulation results of control volume in path shown as chart**



**Fig. 10-36 Simulation results of control volume in path in table**

#### Step 8.4 Simulation results in color gradation

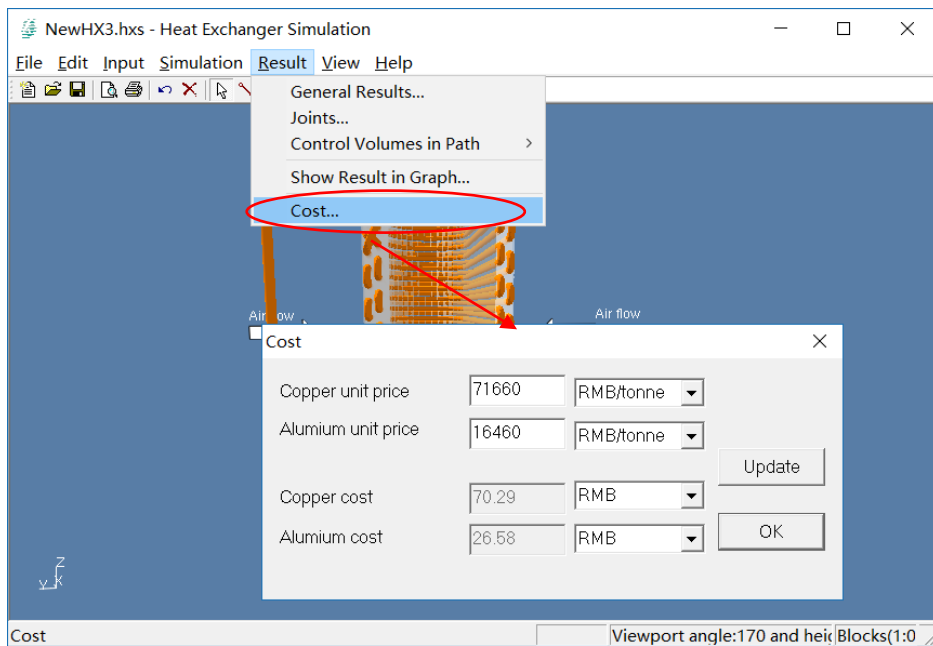
Press menu “**Result | Show results in graph**” to see simulation results of control volumes in chart, just as Fig. 10-37.



**Fig. 10-37 Simulation results in color gradation**

### Step 8.5 Cost

Press menu “**Result | Cost**” to see copper cost and aluminum cost, just as Fig. 10-38.



**Fig. 10-38 Cost**

### 10. 2.9 Step 9: Export Report Form

Click “Export Report Form” to export a report. Capture circuits diagram, preview and edit, then click “print” to export Report form.

Export Report

Choose Export Template

Condenser Template
  Evaporator Template
  Water Coil Template

Preview the Report Form

Please check the form before printing. You may edit the contents until it meets your demands. Double click to edit.

Customer

Date

Project

COIL SIDE			
Fin Type	Louver	Utilized Tubes	20
Fin Material	Aluminum	Non Utilized Tubes	0
Fin Spacing [mm]	1.80	Circuits	2
Fin Thickness [mm]	0.105	Tubes Per Circuit	10.00
Tube Type	Grooved	Coil Length [mm]	500.00
Tube Material	Copper	Coil Depth [mm]	25.40
Tube Dimension [mm]	7.00*0.23*0.10	Coil Height [mm]	210.00
Holes	10	Outer Area [m2]	2.726
Rows	2	Inner Area [m2]	0.205
Tube Vertical Space [mm]	21.00	Coil Face Area [m2]	0.11
Tube Horizontal Space [mm]	12.70	Inner Volume [L]	0.336

Print Current Form

CLOSE

**Fig. 10-39 Select template and print form**

**-End-**